

ASME B16.11-2016
(Revision of ASME B16.11-2011)

Forged Fittings, Socket-Welding and Threaded



AN AMERICAN NATIONAL STANDARD



The American Society of
Mechanical Engineers

WOMIC
沃米克
www.womicsteel.com

ASME B16.11-2016
(Revision of ASME B16.11-2011)

Forged Fittings, Socket-Welding and Threaded



WOMIC
沃米克
www.womicsteel.com

AN AMERICAN NATIONAL STANDARD



The American Society of
Mechanical Engineers

Two Park Avenue • New York, NY • 10016 USA

Date of Issuance: January 20, 2017

The next edition of this Standard is scheduled for publication in 2021.

ASME issues written replies to inquiries concerning interpretations of technical aspects of this Standard. Periodically certain actions of the ASME B16 Committee may be published as Cases. Cases and interpretations are published on the ASME Web site under the Committee Pages at <http://cstools.asme.org/> as they are issued.

Errata to codes and standards may be posted on the ASME Web site under the Committee Pages to provide corrections to incorrectly published items, or to correct typographical or grammatical errors in codes and standards. Such errata shall be used on the date posted.

The Committee Pages can be found at <http://cstools.asme.org/>. There is an option available to automatically receive an e-mail notification when errata are posted to a particular code or standard. This option can be found on the appropriate Committee Page after selecting "Errata" in the "Publication Information" section.

ASME is the registered trademark of The American Society of Mechanical Engineers.

This code or standard was developed under procedures accredited as meeting the criteria for American National Standards. The Standards Committee that approved the code or standard was balanced to assure that individuals from competent and concerned interests have had an opportunity to participate. The proposed code or standard was made available for public review and comment that provides an opportunity for additional public input from industry, academia, regulatory agencies, and the public-at-large.

ASME does not "approve," "rate," or "endorse" any item, construction, proprietary device, or activity.

ASME does not take any position with respect to the validity of any patent rights asserted in connection with any items mentioned in this document, and does not undertake to insure anyone utilizing a standard against liability for infringement of any applicable letters patent, nor assumes any such liability. Users of a code or standard are expressly advised that determination of the validity of any such patent rights, and the risk of infringement of such rights, is entirely their own responsibility.

Participation by federal agency representative(s) or person(s) affiliated with industry is not to be interpreted as government or industry endorsement of this code or standard.

ASME accepts responsibility for only those interpretations of this document issued in accordance with the established ASME procedures and policies, which precludes the issuance of interpretations by individuals.

No part of this document may be reproduced in any form,
in an electronic retrieval system or otherwise,
without the prior written permission of the publisher.

The American Society of Mechanical Engineers
Two Park Avenue, New York, NY 10016-5990

Copyright © 2017 by
THE AMERICAN SOCIETY OF MECHANICAL ENGINEERS
All rights reserved
Printed in U.S.A.

CONTENTS

Foreword	v
Committee Roster	vii
Correspondence With the B16 Committee	viii
Summary of Changes	x
List of Changes in Record Number Order	xii
1 Scope and General	1
2 Pressure Ratings	1
3 Size and Type	8
4 Marking	8
5 Material	9
6 Dimensions	9
7 Additional Tolerances	10
8 Proof Testing	10
Mandatory Appendices	
I Dimensions of Fittings in U.S. Customary Units	11
II References	18
Nonmandatory Appendices	
A Quality System Program	19
Figures	
1 Method of Designating Outlets of Reducing Tees and Crosses	9
2 Welding Gap and Minimum Flat Dimensions for Socket-Welding Fittings	10
Tables	
1 Socket-Welding Elbows, Tees, and Crosses	2
2 Socket-Welding Couplings, Bosses, Caps, and Couplets	3
3 Threaded Elbows, Tees, and Crosses	4
4 Threaded Street Elbows	5
5 Threaded Couplings, Bosses, Caps, and Couplets	6
6 Plugs and Bushings	7
7 Types of Fittings by Class Designation and NPS Size Range	8
8 Correlation of Fittings Class With Schedule Number or Wall Designation of Pipe for Calculation of Ratings	8
9 Nominal Wall Thickness of Schedule 160 and Double Extra Strong Pipe	8
I-1 Socket-Welding Elbows, Tees, and Crosses	12
I-2 Socket-Welding Couplings, Bosses, Caps, and Couplets	13

I-3	Threaded Elbows, Tees, and Crosses	14
I-4	Threaded Street Elbows	15
I-5	Threaded Couplings, Bosses, Caps, and Couplets	16
I-6	Plugs and Bushings	17



Womic
沃米克
www.womicsteel.com

FOREWORD

The Sectional Committee on the Standardization of Pipe Flanges and Fittings, B16, organized in 1920 under the procedure of the American Standards Association (ASA), appointed a subgroup of Subcommittee 3 (now Subcommittee F) to initiate the standardization of welding fittings in May 1937. The first meeting of this group was held later that month, and at its meeting in December 1938, in New York, it was agreed to undertake the standardization of dimensions of socket-welding fittings and to refer this project to a new drafting subgroup. One of the most important dimensions of this type of fitting requiring standardization was considered to be the dimension from the centerline of the fitting to the bottom of the socket, since from the standpoint of the designing engineer, this dimension governs the location of adjacent pipe with reference to the entire piping layout. Another important item for consideration was the welding fillet dimensions.

The drafting subgroup held meetings in Chicago, Detroit, and New York in March 1939 and May and October 1940, respectively, and at the last named meeting, the completed draft of the proposed standard was discussed, and further revisions were suggested. When applied to the September 1940 draft, these changes produced the May 1941 draft, which was prepared for distribution to industry for criticism and comment.

This distribution resulted in a number of helpful comments. The members of the subgroup agreed by mail that many of the changes suggested should be incorporated in the revised draft (December 1941). Progress on the approval of the standard was delayed by the World War II, after which, a few more changes were added to make the proposal acceptable to all concerned. The revised draft (April 1946) was then submitted to the members of the sectional committee for letter ballot vote.

Following the approval of the sectional committee, the proposed standard was next approved by the sponsor bodies and presented to the ASA with recommendation for approval as an American Standard. This designation was given on December 9, 1946.

In 1960, it was agreed that the standard needed a complete revision and simultaneously that it should be expanded to cover threaded fittings and plugs, then covered by MSS SP-49 and SP-50. A Task Force worked diligently for four years before arriving at a draft that was acceptable. They also found that ratings were outdated and eliminated the 4,000-lb classes of threaded fittings, assigned pressure-temperature ratings for a number of materials, and converted the socket-weld fitting ratings to 3,000 and 6,000 lb. Following approval by the Sectional Committee and Sponsors, ASA approval was granted on January 28, 1966.

Following designation changes of ASA to ANSI and Sectional Committee to Standards Committee, Subcommittee 6 began consideration of changes in 1969. Early in 1972, changes in the pressure class designations, materials, and clarification of wording were agreed upon and submitted for approval. This was granted on June 20, 1973.

The work of development of the 1980 edition of B16.11 began in 1975 when the committee began consideration of comments and proposals for change that were received. The development procedure was arduous in that a number of ballots were taken that elicited many additional comments and counterproposals. The major changes included an expanded scope for better definition, requirements for conformance marking, a Nonmandatory Annex with provisions for proof or burst testing, and the inclusion of metric equivalents. Following approval by the Standards Committee and Co-Secretariat, final approval by ANSI was granted on October 6, 1980.

In 1982, American National Standards Committee B16 was reorganized as an ASME Committee operating under procedures accredited by ANSI. The 1991 edition of the standard, retitled "Forged Fittings, Socket-Welding and Threaded," incorporated forging material listed in Table 1 of ASME B16.34-1988, including Group 3 material that was not previously covered in B16.11. The 1991 edition established U.S. Customary units as the standard. Other clarifying and editorial revisions were made to improve the text. Following approval by the Standards Committee and ASME, final approval by ANSI was granted on March 4, 1991.

In 1996, metric dimensions were added as an independent but equal standard to the inch units. Following approval by the Standards Committee and ASME, this revision to the 1991 edition of this Standard was approved as an American National Standard by ANSI on December 16, 1996, with the new designation ASME B16.11-1996.

In 2000, the Standards Committee, ASME, and ANSI approved an addenda to this Standard to remove partial compliance fittings and nonstandard material requirements. Due to an ASME policy change concerning the publishing of addenda, the intended addenda changes were incorporated into the 2001 edition.

Threaded end street elbow requirements were incorporated into the 2004 edition. Following approval by the Standards Committee and ASME, the revision to the 2001 edition was approved as an American National Standard by ANSI on September 30, 2005 with the designation ASME B16.11-2005.

A number of technical revisions were made along with format and reference revisions, such as material marking requirements. Following approval by the Standards Committee and ASME, the revision to the 2005 edition was approved as an American National Standard by ANSI on July 9, 2009 with the designation ASME B16.11-2009.

This revision was approved by the American National Standards Institute on December 2, 2011.

In this 2016 Edition, provisions have been made to update verbiage and readings. Following the approval by the ASME B16 Standards Committee, approval as an American National Standard was given by ANSI on October 21, 2016, with the new designation ASME B16.11-2016.



WOMIC
沃米克
www.womicsteel.com

ASME B16 COMMITTEE

Standardization of Valves, Flanges, Fittings, and Gaskets

(The following is the roster of the Committee at the time of approval of this Standard.)

STANDARDS COMMITTEE OFFICERS

R. M. Bojarczuk, *Chair*
C. E. Davila, *Vice Chair*
C. Ramcharran, *Secretary*

STANDARDS COMMITTEE PERSONNEL

A. Appleton, Alloy Stainless Products Co., Inc.
J. E. Baker, Dezurik Water Controls
R. W. Barnes, Anric Enterprises, Inc.
P. Milankov, *Alternate*, Anric Enterprises, Inc.
K. Barron, Ward Manufacturing
D. C. Bayreuther, Metso Automation, Flow Control Division
W. B. Bedesem, Consultant
R. M. Bojarczuk, ExxonMobil Research and Engineering Co.
A. M. Cheta, Qatar Shell GTL
M. A. Clark, Nibco, Inc.
P. V. Craig, Jomar Group
G. A. Cuccio, Capitol Manufacturing Co.
C. E. Davila, Crane Energy
J. D'Avanzo, Fluoroseal Valves
B. G. Fabian, Pennsylvania Machine Works

F. Feng, China Productivity Center for Machinery
D. R. Frikken, Becht Engineering Co.
R. B. Hai, RBH Associates
G. A. Jolly, Samshin Ltd.
M. Katcher, Haynes International
A. G. Kireta, Jr., Copper Development Association, Inc.
T. A. McMahon, Emerson Process Management
M. L. Nayyar, NICE
W. H. Patrick, The Dow Chemical Co.
D. Raho, CCM 2000
C. Ramcharran, The American Society of Mechanical Engineers
D. F. Reid, VSP Technologies
R. A. Schmidt, Canadoil
J. Tucker, Flowserve
F. R. Volgstadt, Volgstadt and Associates, Inc.

SUBCOMMITTEE F — STEEL THREADED AND WELDING FITTINGS

B. G. Fabian, *Chair*, Pennsylvania Machine Works
R. A. Schmidt, *Vice Chair*, Canadoil
E. Lawson, *Secretary*, The American Society of Mechanical Engineers
A. Appleton, Alloy Stainless Products Co., Inc.
G. A. Cuccio, Capitol Manufacturing Co.
K. W. Doughty, CB&I Alloy Piping Products
J. P. Ellenberger, Retired
D. R. Frikken, Becht Engineering Co.
P. W. Heald, Bonny Forge Co.

D. Hunt, Jr., Fastenal
G. A. Jolly, Samshin Limited
F. Kavarana, CBI Inc.
C. J. Lafferty, U.S. Drop Forge Co.
W. Pritzl, Erne Fittings GmbH
J. P. Tucker, Flowserve Corp.
G. T. Walden, Wolseley
M. M. Zaidi, Jacobs Engineering Group, Inc.

CORRESPONDENCE WITH THE B16 COMMITTEE

General. ASME Standards are developed and maintained with the intent to represent the consensus of concerned interests. As such, users of this Standard may interact with the Committee by requesting interpretations, proposing revisions or a case, and attending Committee meetings. Correspondence should be addressed to:

Secretary, B16 Standards Committee
The American Society of Mechanical Engineers
Two Park Avenue
New York, NY 10016-5990
<http://go.asme.org/Inquiry>

Proposing Revisions. Revisions are made periodically to the Standard to incorporate changes that appear necessary or desirable, as demonstrated by the experience gained from the application of the Standard. Approved revisions will be published periodically.

The Committee welcomes proposals for revisions to this Standard. Such proposals should be as specific as possible, citing the paragraph number(s), the proposed wording, and a detailed description of the reasons for the proposal, including any pertinent documentation.

Proposing a Case. Cases may be issued to provide alternative rules when justified, to permit early implementation of an approved revision when the need is urgent, or to provide rules not covered by existing provisions. Cases are effective immediately upon ASME approval and shall be posted on the ASME Committee Web page.

Requests for Cases shall provide a Statement of Need and Background Information. The request should identify the Standard and the paragraph, figure, or table number(s), and be written as a Question and Reply in the same format as existing Cases. Requests for Cases should also indicate the applicable edition(s) of the Standard to which the proposed Case applies.

Interpretations. Upon request, the B16 Standards Committee will render an interpretation of any requirement of the Standard. Interpretations can only be rendered in response to a written request sent to the Secretary of the B16 Standards Committee.

Requests for interpretation should preferably be submitted through the online Interpretation Submittal Form. The form is accessible at <http://go.asme.org/InterpretationRequest>. Upon submittal of the form, the Inquirer will receive an automatic e-mail confirming receipt.

If the Inquirer is unable to use the online form, he/she may e-mail the request to the Secretary of the B16 Standards Committee at SecretaryB16@asme.org, or mail it to the above address. The request for an interpretation should be clear and unambiguous. It is further recommended that the Inquirer submit his/her request in the following format:

Subject: Cite the applicable paragraph number(s) and the topic of the inquiry in one or two words.
Edition: Cite the applicable edition of the Standard for which the interpretation is being requested.
Question: Phrase the question as a request for an interpretation of a specific requirement suitable for general understanding and use, not as a request for an approval of a proprietary design or situation. Please provide a condensed and precise question, composed in such a way that a "yes" or "no" reply is acceptable.
Proposed Reply(ies): Provide a proposed reply(ies) in the form of "Yes" or "No," with explanation as needed. If entering replies to more than one question, please number the questions and replies.
Background Information: Provide the Committee with any background information that will assist the Committee in understanding the inquiry. The Inquirer may also include any plans or drawings that are necessary to explain the question; however, they should not contain proprietary names or information.

Requests that are not in the format described above may be rewritten in the appropriate format by the Committee prior to being answered, which may inadvertently change the intent of the original request.

ASME procedures provide for reconsideration of any interpretation when or if additional information that might affect an interpretation is available. Further, persons aggrieved by an interpretation may appeal to the cognizant ASME Committee or Subcommittee. ASME does not “approve,” “certify,” “rate,” or “endorse” any item, construction, proprietary device, or activity.

Attending Committee Meetings. The B16 Standards Committee regularly holds meetings and/or telephone conferences that are open to the public. Persons wishing to attend any meeting and/or telephone conference should contact the Secretary of the B16 Standards Committee.



WOMIC
沃米克
www.womicsteel.com

ASME B16.11-2016 SUMMARY OF CHANGES

Following approval by the ASME B16 Committee and ASME, and after public review, ASME B16.11-2016 was approved by the American National Standards Institute on October 21, 2016.

ASME B16.11-2016 includes the following changes identified by a margin note, **(16)**. The Record Number listed below is explained in more detail in the "List of Changes in Record Number Order" following this Summary of Changes.

<i>Page</i>	<i>Location</i>	<i>Change</i>
2	Table 1	Title and table revised in its entirety (12-389)
3	Table 2	New Table 2 added; previous Table 2 redesignated as Table 3 and revised in its entirety (12-389)
4	Table 3	Redesignated as Table 4 and title revised (12-389)
4	2.2	Revised in its entirety (13-632)
5	Table 4	(1) Redesignated as Table 5 (12-389) (2) Title and table revised in its entirety (12-389) (3) Under Nominal Pipe Size $\frac{1}{8}$, entries added for Class 6000 for End-to-End Caps, <i>P</i> , and Minimum End Wall Thickness, <i>G</i> (16-351)
6	Table 5	(1) Redesignated as Table 6 (12-389) (2) Under Nominal Pipe Size 2, entry for Minimum Width Flats, <i>C</i> , revised (16-351)
7	Table 6	(1) Redesignated as Table 7 (12-389) (2) First entry under Description revised (16-351)
8	Table 7	Redesignated as Table 8 (12-389)
8	Table 8	Redesignated as Table 9 (12-389)
8	Table 9	Redesignated from previous Table 8 (12-389)
9	5.1	Last sentence revised (15-2823)
12	Table I-1	Title and table revised in its entirety (12-389)
13	Table I-2	New Table I-2 added; previous Table I-2 redesignated as Table I-3 and revised in its entirety (12-389)
14	Table I-3	Redesignated as Table I-4 (12-389)
15	Table I-4	(1) Redesignated as Table I-5 (12-389) (2) Title and table revised in its entirety (12-389)

16
18

Table I-5
Mandatory Appendix II

(3) Under Normal Pipe Size $\frac{1}{8}$, entries added
for Class 6000 for End-to-End Caps, *P*, and
Minimum End Wall Thickness, *G* (16-351)
Redesignated as Table I-6 (12-389)
References updated (16-829)



Womic
沃米克
www.womicsteel.com

LIST OF CHANGES IN RECORD NUMBER ORDER

Record Number	Change
12-389	Updated tables inserted throughout document
13-632	To clarify and correct para 5.1 in B16.11-2011 language so as to not disallow bar stock as a starting material.
15-2823	NPS $\frac{1}{8}$ Class 6000 cap dimensions added to Tables 5 and I-5, since the Standard has requirements for outside diameter dimension listed for NPS $\frac{1}{8}$ Class 6000 couplings, half couplings, and caps; and in Table 7 indicates Class 6000 couplings and half-couplings are available in NPS $\frac{1}{8}$ -4
16-351	Table 5 data
16-829	Mandatory Appendix II references updated



Womic
沃米克
www.womicsteel.com

FORGED FITTINGS, SOCKET-WELDING AND THREADED

1 SCOPE AND GENERAL

1.1 Scope

This Standard covers ratings, dimensions, tolerances, marking, and material requirements for forged fittings, both socket-welding and threaded, as illustrated in [Tables 1 through 6](#) and [Tables I-1 through I-6](#), inclusive.

1.1.1 Fitting Types/Configuration. Types of fittings covered by this Standard are shown in [Table 7](#), by class and size range. Fittings shown in [Tables 1 through 6](#) and [Tables I-1 through I-6](#) may also be made with combinations of socket-welding and threaded ends.

1.1.2 Special Fittings. Fittings with special dimensions, threads, or counterbores may be made by agreement between the manufacturer and purchaser. When such fittings meet all other stipulations of this Standard, they shall be considered in compliance therewith, provided they are appropriately marked (see [section 4](#)).

1.1.3 Welding. Installation welding requirements are not within the scope of this Standard. Installation welding shall be in accordance with the applicable piping Code or regulation covering the piping system into which the fittings are installed.

1.2 General

1.2.1 Referenced Standards. Standards and specifications adopted by reference in this Standard are shown in [Mandatory Appendix II](#). It is not considered practical to identify the specific edition of each standard and specification in the individual references. Instead, the specific edition reference is identified in [Mandatory Appendix II](#). A fitting made in conformance and conforming to this Standard, in all other respects, will be considered to be in conformance to the Standard, even though the edition reference may be changed in a subsequent revision of the Standard.

1.2.2 Codes and Regulations. A fitting used under the jurisdiction of the ASME Boiler and Pressure Vessel Code, the ASME Code for Pressure Piping, or a governmental regulation is subject to any limitation of that code or regulation. This includes any maximum temperature limitation, rule governing the use of a material at low temperature, or provisions for operation at a pressure exceeding the ratings in this Standard.

1.2.3 Service Conditions. Criteria for selection of fitting types and materials suitable for particular fluid service are not within the scope of this Standard.

1.2.4 Quality Systems. Nonmandatory requirements relating to the product manufacturer's quality system program are described in [Nonmandatory Appendix A](#).

1.2.5 Relevant Units. This Standard states values in both SI (Metric) and U.S. Customary units. These systems of units are to be regarded separately as standard. Within the text, the U.S. Customary units are shown in parentheses or in separate tables that appear in [Mandatory Appendix I](#). The values stated in each system are not exact equivalents; therefore, it is required that each system of units be used independently of the other. Combining values from the two systems constitutes nonconformance with the Standard.

[Tables 1 through 6](#) show fittings dimensional requirements in millimeters. [Tables I-1 through I-6](#) show the dimensional requirements for inch dimensioned fittings.

2 PRESSURE RATINGS

2.1 General

Fittings under this Standard shall be designated as Class 2000, 3000, and 6000 for threaded end fittings and Class 3000, 6000, and 9000 for socket-weld end fittings.

2.1.1 Basis of Rating. The schedule of pipe corresponding to each Class designation of fitting for rating purposes is shown in [Table 8](#). Design temperature and other service conditions shall be limited as provided by the applicable piping code or regulation for the material of construction of the fitting. Within these limits, the minimum wall thickness for pipe to be used with a [Table 8](#) Class designated fitting shall be computed based on appropriate size straight seamless pipe of equivalent material as the fitting (as shown by comparison of composition and mechanical properties in the respective material specifications). The minimum pipe wall thickness calculation shall include pressure design and all applicable additional allowances (e.g., erosion, corrosion, and thread depth for threaded pipe). The minimum wall thickness for selected pipe, considering manufacturing minus wall thickness tolerance (typically 12.5%), shall not be less than the minimum wall calculation. The fitting is suitable for the application if the wall thickness of the selected pipe equals or is less than the ASME B36.10M Schedule No. or Wall Designation pipe wall thickness correlated with the fitting in [Table 8](#) [see [Note \(1\)](#) in [Table 8](#)].

(16)

Table 1 Socket-Welding Elbows, Tees, and Crosses

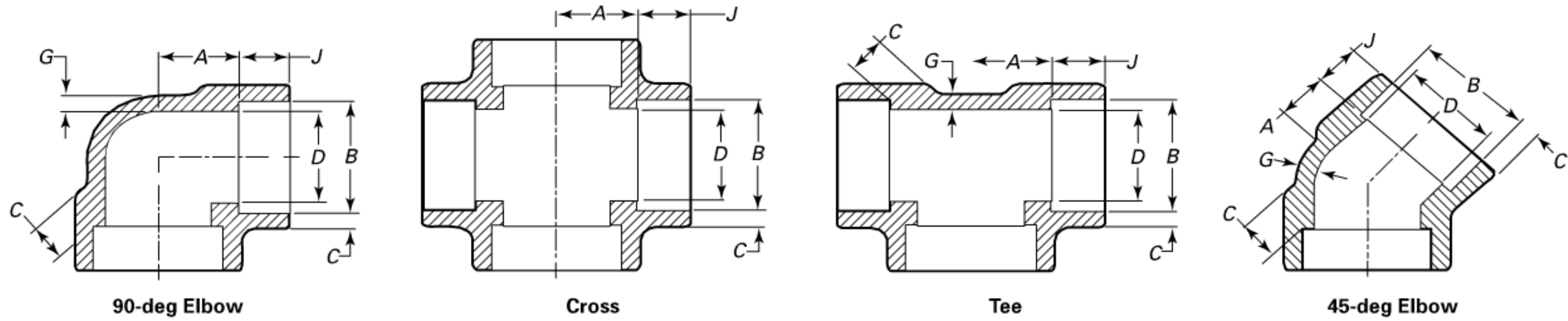

Nominal Pipe Size	Socket Bore Diam., B		Bore Diameter of Fittings, D						Socket Wall Thickness, C [Note (1)]						Body Wall, G			Socket Depth, J	Center-to-Bottom of Socket, A						
			3000		6000		9000		3000		6000		9000		3000	6000	9000		90 El, Cross, Tee			45-deg Elbow			Tol ±
	Max.	Min.	Max.	Min.	Max.	Min.	Max.	Min.	Avg.	Min.	Avg.	Min.	Avg.	Min.	Min.	Min.	Min.	3000	6000	9000	3000	6000	9000		
1/8	11.2	10.8	7.6	6.1	4.8	3.2	3.18	3.18	3.96	3.43	2.41	3.15	...	9.5	11.0	11.0	...	8.0	8.0	...	1.0
1/4	14.6	14.2	10.0	8.5	7.1	5.6	3.78	3.30	4.60	4.01	3.02	3.68	...	9.5	11.0	13.5	...	8.0	8.0	...	1.0
3/8	18.0	17.6	13.3	11.8	9.9	8.4	4.01	3.50	5.03	4.37	3.20	4.01	...	9.5	13.5	15.5	...	8.0	11.0	...	1.5
1/2	22.2	21.8	16.6	15.0	12.5	11.0	7.2	5.6	4.67	4.09	5.97	5.18	9.35	8.18	3.73	4.78	7.47	9.5	15.5	19.0	25.5	11.0	12.5	15.5	1.5
3/4	27.6	27.2	21.7	20.2	16.3	14.8	11.8	10.3	4.90	4.27	6.96	6.04	9.78	8.56	3.91	5.56	7.82	12.5	19.0	22.5	28.5	13.0	14.0	19.0	1.5
1	34.3	33.9	27.4	25.9	21.5	19.9	16.0	14.4	5.69	4.98	7.92	6.93	11.38	9.96	4.55	6.35	9.09	12.5	22.5	27.0	32.0	14.0	17.5	20.5	2.0
1 1/4	43.1	42.7	35.8	34.3	30.2	28.7	23.5	22.0	6.07	5.28	7.92	6.93	12.14	10.62	4.85	6.35	9.70	12.5	27.0	32.0	35.0	17.5	20.5	22.5	2.0
1 1/2	49.2	48.8	41.6	40.1	34.7	33.2	28.7	27.2	6.35	5.54	8.92	7.80	12.70	11.12	5.08	7.14	10.15	12.5	32.0	38.0	38.0	20.5	25.5	25.5	2.0
2	61.7	61.2	53.3	51.7	43.6	42.1	38.9	37.4	6.93	6.04	10.92	9.50	13.84	12.12	5.54	8.74	11.07	16.0	38.0	41.0	54.0	25.5	28.5	28.5	2.0
2 1/2	74.4	73.9	64.2	61.2	8.76	7.67	7.01	16.0	41.0	28.5	2.5
3	90.3	89.8	79.4	76.4	9.52	8.30	7.62	16.0	57.0	32.0	2.5
4	115.7	115.2	103.8	100.7	10.69	9.35	8.56	19.0	66.5	41.0	2.5

GENERAL NOTE: Dimensions are in millimeters.

NOTE: (1) Average of socket wall thickness around periphery shall not be less than listed values. The minimum values are permitted in localized areas.

(16)

Table 2 Socket-Welding Couplings, Bosses, Caps, and Couplets

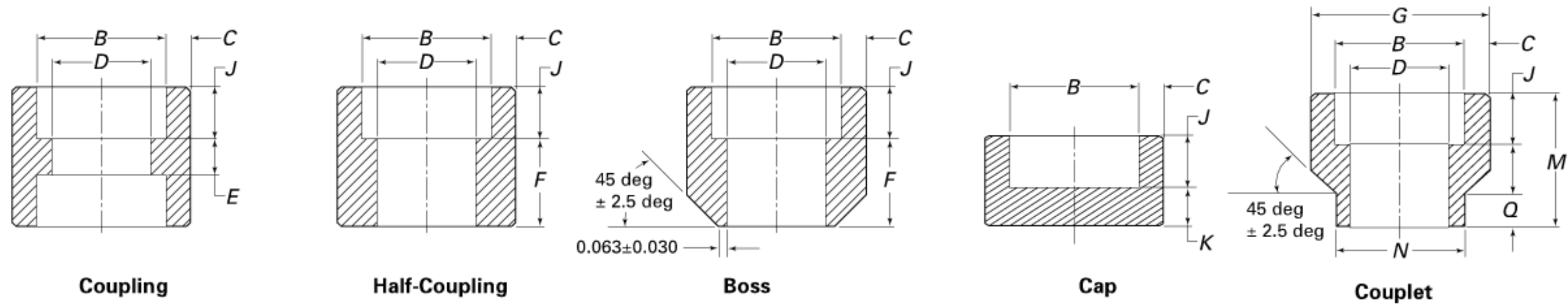

Nominal Pipe Size	Socket Bore Dia., <i>B</i>		Bore Diameter of Fittings, <i>D</i>						Socket Wall Thickness, [Note (1)], <i>C</i>						Outside Dia. Couplet, <i>G</i>		Socket Depth, <i>J</i>	Laying Lgth., <i>E</i> Tol.	Laying Lgth., <i>F</i> Tol.	End Wall Thickness, <i>K</i>			End to End Couplet, <i>M</i> Tol.	Weld Ring Diameter, <i>N</i> Tol.	Weld Ring Length, <i>Q</i>							
	Max.	Min.	3000		6000		9000		3000	6000	9000	3000	6000	±	Min.	±				±	3000	6000			9000	±	±	3000/ 6000	±			
			Max.	Min.	Max.	Min.	Max.	Min.																						Avg.	Min.	Avg.
1/8	11.2	10.8	7.6	6.1	4.8	3.2	3.18	3.18	3.96	3.43	±1.5/-0.0	9.5	6.5	1.5	16.0	1.5	4.8	6.4
1/4	14.6	14.2	10.0	8.5	7.1	5.6	3.78	3.30	4.60	4.01	23.8	25.4	±1.5/-0.0	9.5	6.5	1.5	16.0	1.5	4.8	6.4	...	30.2	±0.8/-0.0	17.5	±1.5/-0.0	9.5	0.8	
3/8	18.0	17.6	13.3	11.8	9.9	8.4	4.01	3.50	5.03	4.37	27.0	31.8	±1.5/-0.0	9.5	6.5	3.0	17.5	3.0	4.8	6.4	...	30.2	±0.8/-0.0	20.7	±1.5/-0.0	9.5	0.8	
1/2	22.2	21.8	16.6	15.0	12.5	11.0	7.2	5.6	4.67	4.09	5.97	5.18	9.35	8.18	33.4	38.1	±1.5/-0.0	9.5	9.5	3.0	22.5	3.0	6.4	7.9	11.2	33.4	±0.8/-0.0	23.8	±1.5/-0.0	9.5	0.8	
3/4	27.6	27.2	21.7	20.2	16.3	14.8	11.8	10.3	4.90	4.27	6.96	6.04	9.78	8.56	38.1	44.5	±1.5/-0.0	12.5	9.5	3.0	24.0	3.0	6.4	7.9	12.7	34.9	±0.8/-0.0	27.0	±1.5/-0.0	9.5	0.8	
1	34.3	33.9	27.4	25.9	21.5	19.9	16.0	14.4	5.69	4.98	7.92	6.93	11.38	9.96	46.1	57.2	±1.5/-0.0	12.5	12.5	4.0	28.5	4.0	9.6	11.2	14.2	47.6	±0.8/-0.0	42.9	±1.5/-0.0	9.5	0.8	
1 1/4	43.1	42.7	35.8	34.3	30.2	28.7	23.5	22.0	6.07	5.28	7.92	6.93	12.14	10.62	55.6	63.5	±1.5/-0.0	12.5	12.5	4.0	30.0	4.0	9.6	11.2	14.2	47.6	±0.8/-0.0	42.9	±1.5/-0.0	9.5	0.8	
1 1/2	49.2	48.8	41.6	40.1	34.7	33.2	28.7	27.2	6.35	5.54	8.92	7.80	12.70	11.12	63.5	76.2	±1.5/-0.0	12.5	12.5	4.0	32.0	4.0	11.2	12.7	15.7	50.8	±0.8/-0.0	49.2	±1.5/-0.0	9.5	0.8	
2	61.7	61.2	53.3	51.7	43.6	42.1	38.9	37.4	6.93	6.04	10.92	9.50	13.84	12.21	79.4	92.1	±1.5/-0.0	16.0	19.0	4.0	41.0	4.0	12.7	15.7	19.0	57.2	±1.5/-0.0	61.9	±1.5/-0.0	9.5	0.8	
2 1/2	74.4	73.9	64.2	61.2	8.76	7.67	92.1	108.0	±1.5/-0.0	16.0	19.0	5.0	43.0	5.0	15.7	19.0	...	63.5	±1.5/-0.0	73.0	±1.5/-0.0	9.5	0.8	
3	90.3	89.8	79.4	76.4	9.52	8.30	111.1	127.0	±1.5/-0.0	16.0	19.0	5.0	44.5	5.0	19.0	22.4	...	69.9	±1.5/-0.0	88.9	±1.5/-0.0	9.5	0.8	
4	115.7	115.2	103.8	100.7	10.69	9.35	141.3	158.8	±1.5/-0.0	19.0	19.0	5.0	48.0	5.0	22.4	28.4	...	76.2	±1.5/-0.0	114.3	±1.5/-0.0	9.5	0.8	

GENERAL NOTE: Dimensions are in millimeters.

NOTE: (1) Average of socket wall thickness around periphery shall not be less than listed values. The minimum values are permitted in localized areas.

(16)

Table 3 Threaded Elbows, Tees, and Crosses

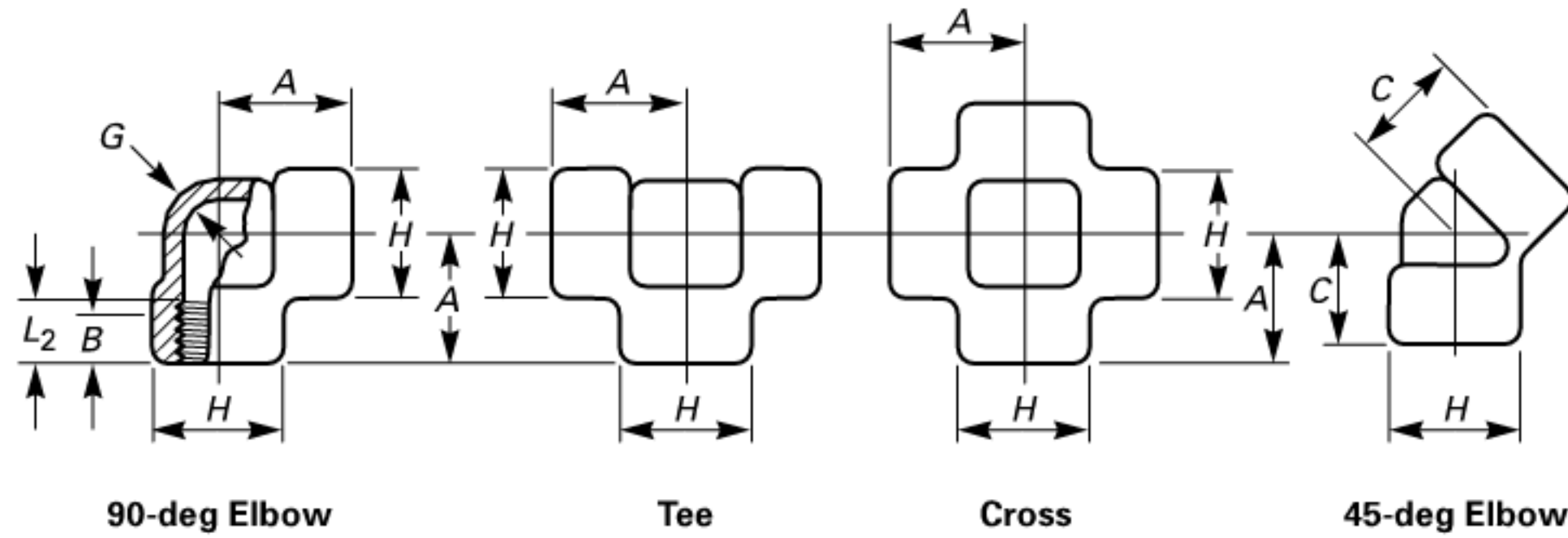

Nominal Pipe Size	Center-to-End Elbows, Tees, and Crosses, A			Center-to-End 45-deg Elbow, C			Outside Diameter of Band, H			Minimum Wall Thickness, G			Minimum Length of Thread [Note (1)]	
	2000	3000	6000	2000	3000	6000	2000	3000	6000	2000	3000	6000	B	L ₂
1/8	21	21	25	17	17	19	22	22	25	3.18	3.18	6.35	6.4	6.7
1/4	21	25	28	17	19	22	22	25	33	3.18	3.30	6.60	8.1	10.2
3/8	25	28	33	19	22	25	25	33	38	3.18	3.51	6.98	9.1	10.4
1/2	28	33	38	22	25	28	33	38	46	3.18	4.09	8.15	10.9	13.6
3/4	33	38	44	25	28	33	38	46	56	3.18	4.32	8.53	12.7	13.9
1	38	44	51	28	33	35	46	56	62	3.68	4.98	9.93	14.7	17.3
1 1/4	44	51	60	33	35	43	56	62	75	3.89	5.28	10.59	17.0	18.0
1 1/2	51	60	64	35	43	44	62	75	84	4.01	5.56	11.07	17.8	18.4
2	60	64	83	43	44	52	75	84	102	4.27	7.14	12.09	19.0	19.2
2 1/2	76	83	95	52	52	64	92	102	121	5.61	7.65	15.29	23.6	28.9
3	86	95	106	64	64	79	109	121	146	5.99	8.84	16.64	25.9	30.5
4	106	114	114	79	79	79	146	152	152	6.55	11.18	18.67	27.7	33.0

GENERAL NOTE: Dimensions are in millimeters.

NOTE: (1) Dimension B is minimum length of perfect thread. The length of useful thread (B plus threads with fully formed roots and flat crests) shall not be less than L₂ (effective length of external thread) required by American National Standard for Pipe Threads (ASME B1.20.1; see para. 6.3).

2.1.2 Nonstandard Pipe Wall Thickness. Since ASME B36.10M does not include Schedule 160 nor Double Extra Strong thickness for NPS 1/8, 1/4, and 3/8, the values in Table 9 shall be used as the nominal wall thicknesses of the pipe for rating purposes.

2.1.3 Combination End Fittings. The Class designation for fittings made with combinations of socket-welding and threaded ends shall be based on the end configuration that has the lowest rating from Table 8.

(16) 2.2 Wall Thickness Design for Special Dimension Pipe

2.2.1 As these fittings are to be used in connection with pipe, the minimum body wall thickness for socket-welding fittings must be equal to or greater than the nominal wall thickness of the pipe with which they are used.

2.2.2 The average socket wall thickness shall at least equal 1.25 times the nominal thickness of the corresponding pipe, and at no point shall the minimum thickness be less than 1.09 times the nominal pipe wall thickness (which is $1.25 \times 0.875 \times$ nominal pipe wall).

2.2.3 The minimum body wall thickness for threaded fittings shall be equal to or greater than the nominal wall thickness of the pipe with which they are used.

2.3 Pressure Test Capability

Pressure testing is not required by this Standard, but the fittings shall be capable of withstanding a hydrostatic test pressure required by the applicable piping code for seamless pipe of material equivalent to the fitting forging and of the schedule or wall thickness correlated with the fitting Class and end connection of Table 8.

(16)

Table 4 Threaded Street Elbows

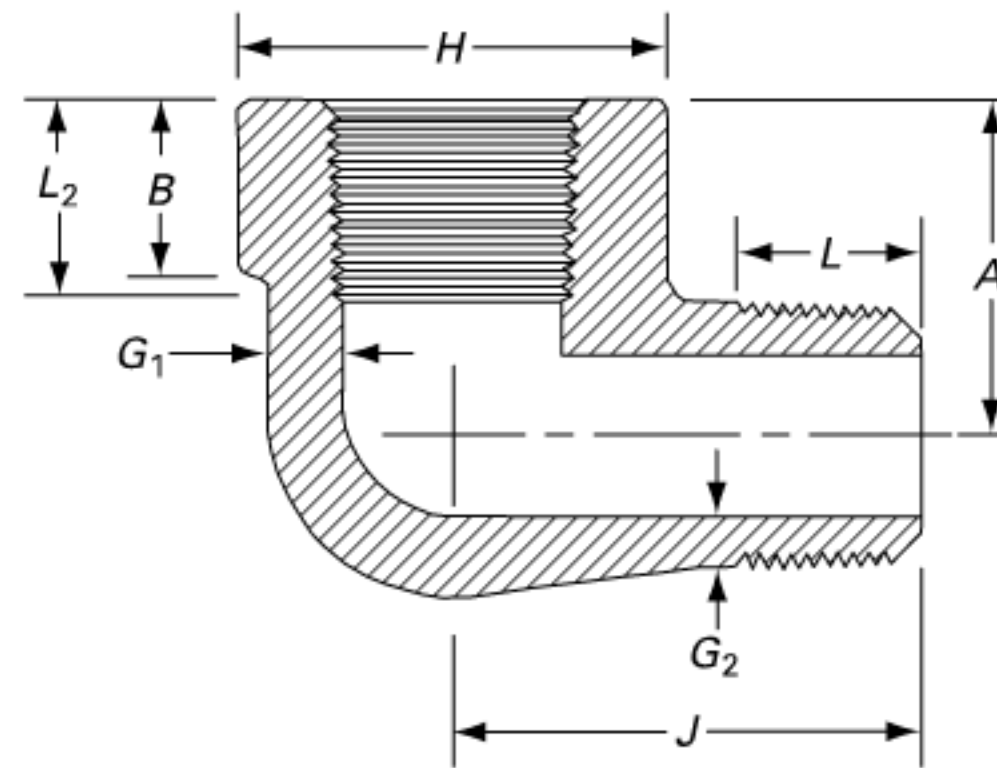

Nominal Pipe Size, NPS	Center-to-Female End Street Ells, A [Note (1)]		Center-to-Male End Street Ells, J		Outside Diameter of Band, H [Note (2)]		Minimum Wall Thickness, G_1		Minimum Wall Thickness, G_2 [Note (3)]		Minimum Length Internal Thread [Note (4)]		Minimum Length Male Thread, L
	Class Designation		Class Designation		Class Designation		Class Designation		Class Designation		B	L_2	
	3000	6000	3000	6000	3000	6000	3000	6000	3000	6000			
1/8	19	22	25	32	19	25	3.18	5.08	2.74	4.22	6.4	6.7	10
1/4	22	25	32	38	25	32	3.30	5.66	3.22	5.28	8.1	10.2	11
3/8	25	28	38	41	32	38	3.51	6.98	3.50	5.59	9.1	10.4	13
1/2	28	35	41	48	38	44	4.09	8.15	4.16	6.53	10.9	13.6	14
3/4	35	44	48	57	44	51	4.32	8.53	4.88	6.86	12.7	13.9	16
1	44	51	57	66	51	62	4.98	9.93	5.56	7.95	14.7	17.3	19
1 1/4	51	54	66	71	62	70	5.28	10.59	5.56	8.48	17.0	18.0	21
1 1/2	54	64	71	84	70	84	5.56	11.07	6.25	8.89	17.8	18.4	21
2	64	83	84	105	84	102	7.14	12.09	7.64	9.70	19.0	19.2	22

GENERAL NOTE: Dimensions are in millimeters.

NOTES:

- (1) Dimension A of Table 2 for the appropriate fitting size may also be used at the option of the manufacturer.
- (2) Dimension H of Table 2 for the appropriate fitting size may also be used at the option of the manufacturer.
- (3) Wall thickness before threading.
- (4) Dimension B is minimum length of perfect thread. The length of useful thread (B plus threads with fully formed roots and flat crests) shall not be less than L_2 (effective length of external thread) required by American National Standard for Pipe Threads (ASME B1.20.1; see para. 6.3).

(16)

Table 5 Threaded Couplings, Bosses, Caps, and Couplets

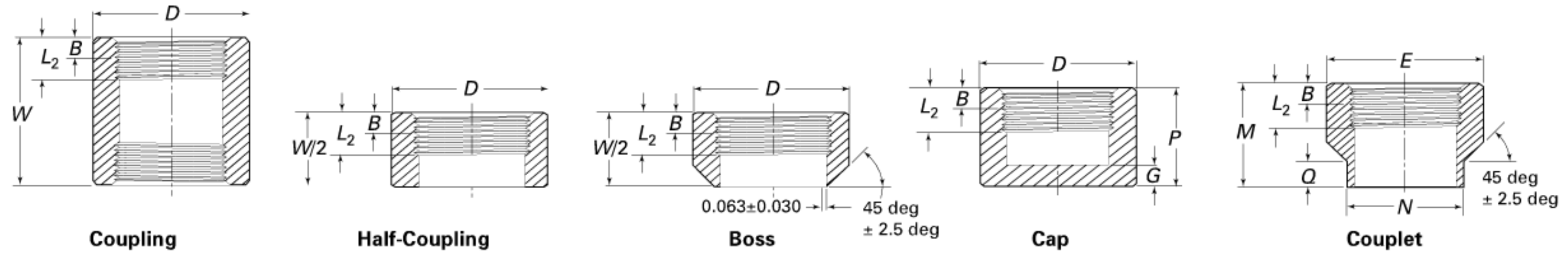

Nominal Pipe Size	Outside Diameter, D		Outside Diameter Couplet, E		Tol. \pm	End-to- End Coupling, W	End-to-End Caps, P		End-to-End Coupling		Tol. \pm	Minimum End Wall Thickness, G		Weld Ring Length, Q		Tol. \pm	Weld Ring Diameter, N		Tol. \pm	Minimum Length of Thread [Note (1)]	
	3000	6000	3000	6000			3000	6000	3000/ 6000	3000		6000	3000/ 6000	3000	6000		3000/ 6000	3000/ 6000		3000/ 6000	3000/ 6000
	$\frac{1}{8}$	16	22	32	19	22	4.8	6.4	6.4	6.7	
$\frac{1}{4}$	19	25	23.8	25.4	$\pm 1.5/-0.0$	35	25	27	30.2	$\pm 0.8/-0.0$	4.8	6.4	9.5	0.8	17.5	$\pm 1.5/-0.0$	8.1	10.2			
$\frac{3}{8}$	22	32	27.0	31.8	$\pm 1.5/-0.0$	48	32	27	30.2	$\pm 0.8/-0.0$	4.8	6.4	9.5	0.8	20.7	$\pm 1.5/-0.0$	9.1	10.4			
$\frac{1}{2}$	28	38	33.4	38.1	$\pm 1.5/-0.0$	48	32	33	33.4	$\pm 0.8/-0.0$	6.4	7.9	9.5	0.8	23.8	$\pm 1.5/-0.0$	10.9	13.6			
$\frac{3}{4}$	35	44	38.1	44.5	$\pm 1.5/-0.0$	51	37	38	34.9	$\pm 0.8/-0.0$	6.4	7.9	9.5	0.8	27.0	$\pm 1.5/-0.0$	12.7	13.9			
1	44	57	46.1	57.2	$\pm 1.5/-0.0$	60	41	43	42.9	$\pm 0.8/-0.0$	9.7	11.2	9.5	0.8	33.4	$\pm 1.5/-0.0$	14.7	17.3			
$1\frac{1}{4}$	57	64	55.6	63.5	$\pm 1.5/-0.0$	67	44	46	47.6	$\pm 0.8/-0.0$	9.7	11.2	9.5	0.8	42.9	$\pm 1.5/-0.0$	17.0	18.4			
$1\frac{1}{2}$	64	76	63.5	76.2	$\pm 1.5/-0.0$	79	44	48	50.8	$\pm 0.8/-0.0$	11.2	12.7	9.5	0.8	49.2	$\pm 1.5/-0.0$	17.8	18.4			
2	76	92	79.4	79.4	$\pm 1.5/-0.0$	86	48	51	57.2	$\pm 1.5/-0.0$	12.7	15.7	9.5	0.8	61.9	$\pm 1.5/-0.0$	19.0	19.2			
$2\frac{1}{2}$	92	108	92.1	92.1	$\pm 1.5/-0.0$	92	60	64	63.5	$\pm 1.5/-0.0$	15.7	19.0	9.5	0.8	73.0	$\pm 1.5/-0.0$	23.6	28.9			
3	108	127	111.1	111.1	$\pm 1.5/-0.0$	108	65	68	69.9	$\pm 1.5/-0.0$	19.0	22.4	9.5	0.8	114.3	$\pm 1.5/-0.0$	25.9	30.5			
4	140	159	141.3	141.3	$\pm 1.5/-0.0$	121	68	75	76.2	$\pm 1.5/-0.0$	22.4	28.4	9.5	0.8	114.3	$\pm 1.5/-0.0$	27.7	33.0			

GENERAL NOTES:

(a) Dimensions are in millimeters.

(b) The wall thickness away from the threaded ends shall meet the minimum wall thickness requirements of Table 1-2 for the appropriate NPS and Class Designation fitting.

NOTE: (1) Dimension B is minimum length of perfect thread. The length of useful thread (B plus threads with fully formed roots and flat crests) shall not be less than L_2 (effective length of external thread) required by American National Standard for Pipe Threads (ASME B1.20.1; see para. 6.3).

(16)

Table 6 Plugs and Bushings

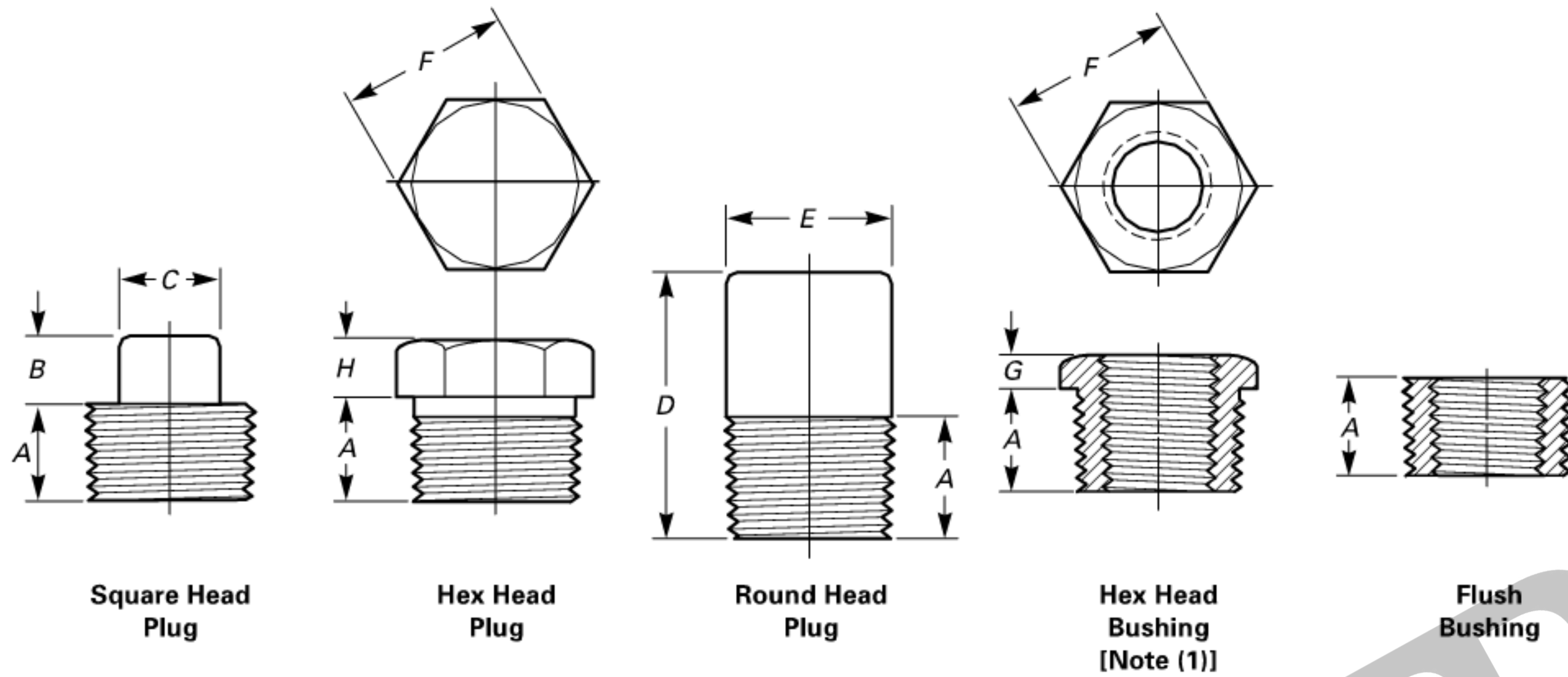

Nominal Pipe Size	Square Head Plugs			Round Head Plugs		Hex Plugs and Bushings		
	Minimum Length, <i>A</i>	Minimum Square Height, <i>B</i>	Minimum Width Flats, <i>C</i> [Note (2)]	Nominal Head Diameter, <i>E</i>	Minimum Length, <i>D</i>	Nominal Width Flats, <i>F</i> [Note (2)]	Minimum Hex Height	
							Bushing, <i>G</i>	Plug, <i>H</i>
1/8	10	6	7.15	10	35	11.11	...	6
1/4	11	6	9.55	14	41	15.88	3	6
3/8	13	8	11.11	18	41	17.46	4	8
1/2	14	10	14.29	21	44	22.23	5	8
3/4	16	11	15.88	27	44	26.99	6	10
1	19	13	20.64	33	51	34.93	6	10
1 1/4	21	14	23.81	43	51	44.45	7	14
1 1/2	21	16	28.58	48	51	50.80	8	16
2	22	18	33.27	60	64	63.50	9	18
2 1/2	27	19	38.10	73	70	76.20	10	19
3	28	21	42.86	89	70	88.90	10	21
4	32	25	63.50	114	76	117.48	13	25

GENERAL NOTE: Dimensions are in millimeters.

NOTES:

- (1) *Cautionary Note Regarding Hex Bushings:* Hex head bushings of one-size reduction should not be used in services where they might be subject to harmful loads and forces other than internal pressures.
- (2) Manufacturer's applied tolerance shall ensure dimension will fit U.S. Customary tooling.

(16) **Table 7 Types of Fittings by Class Designation and NPS Size Range**

Description	Socket-Welding			Threaded		
	Class Designation			Class Designation		
	3000	6000	9000	2000	3000	6000
45-deg, 90-deg elbows, tees, crosses, couplings, half-couplings, caps, bosses, and couplets	1/8-4	1/8-2	1/2-2	1/8-4	1/8-4	1/8-4
	1/8-4	1/8-2	1/2-2	1/8-4	1/8-4	1/8-4
	1/8-4	1/8-2	1/2-2	...	1/8-4	1/8-4
	1/8-4	1/8-2	1/2-2	...	1/8-4	1/4-2
Street elbows	1/8-2	1/8-2
Square, hex, round plug, hex, and flush bushing	1/8-4 [Note (1)]	1/8-4 [Note (1)]	1/8-4 [Note (1)]
	1/8-4 [Note (1)]	1/8-4 [Note (1)]	1/8-4 [Note (1)]

NOTE: (1) Plugs and bushings are not identified by class designation. They may be used for ratings up to Class 6000 designation.

3 SIZE AND TYPE

3.1 General

NPS, followed by a dimensionless number, is the designation for nominal fitting size. NPS is related to the reference nominal diameter, DN, used in international standards. The relationship is typically as follows:

NPS	DN
1/8	6
1/4	8
3/8	10
1/2	15
3/4	20
1	25
1 1/4	32
1 1/2	40
2	50
2 1/2	65
3	80
4	100

3.2 Reducing Fitting Size

In the case of reducing tees and crosses, the size of the largest run opening shall be given first, followed by the size of the opening at the opposite end of the run. Where the fitting is a tee, the size of the branch is given last. Where the fitting is a cross, the largest side-outlet is the third dimension given, followed by the opening opposite. The line sketches, Figure 1, illustrate how the reducing fittings are read.

4 MARKING

4.1 General

Each fitting shall be permanently marked with the required identification by raised lettering and/or stamping, electro-etching, or vibro-tool marking on the collar portion, raised pad, or raised boss portion of the

forging. Cylindrical fittings shall be marked on the O.D. or end of the fitting in a location such that the marking will not be obliterated as a result of welding installation. The marking of bushings and plugs is not required by this Standard.

4.1.1 Specific Marking. The marking shall include (but is not limited to) the following:

- (a) *Manufacturer's Name or Trademark*
- (b) *Material Identification.* Material shall be identified in accordance with the marking requirements of either the appropriate ASTM Fitting or Forging Specifications (see para. 5.1).

Table 8 Correlation of Fittings Class With Schedule Number or Wall Designation of Pipe for Calculation of Ratings (16)

Class Designation of Fitting	Type of Fitting	Pipe Used for Rating Basis [Note (1)]	
		Schedule No.	Wall Designation
2000	Threaded	80	XS
3000	Threaded	160	...
6000	Threaded	...	XXS
3000	Socket-welding	80	XS
6000	Socket-welding	160	...
9000	Socket-welding	...	XXS

NOTE: (1) This Table is not intended to restrict the use of pipe of thinner or thicker wall with fittings. Pipe actually used may be thinner or thicker in nominal wall than that shown in Table 8. When thinner pipe is used, its strength may govern the rating. When thicker pipe is used (e.g., for mechanical strength), the strength of the fitting governs the rating.

Table 9 Nominal Wall Thickness of Schedule 160 and Double Extra Strong Pipe (16)

NPS	Schedule 160		XXS	
	mm	in.	mm	in.
1/8	3.15	0.124	4.83	0.190
1/4	3.68	0.145	6.05	0.238
3/8	4.01	0.158	6.40	0.252

Figure 1 Method of Designating Outlets of Reducing Tees and Crosses

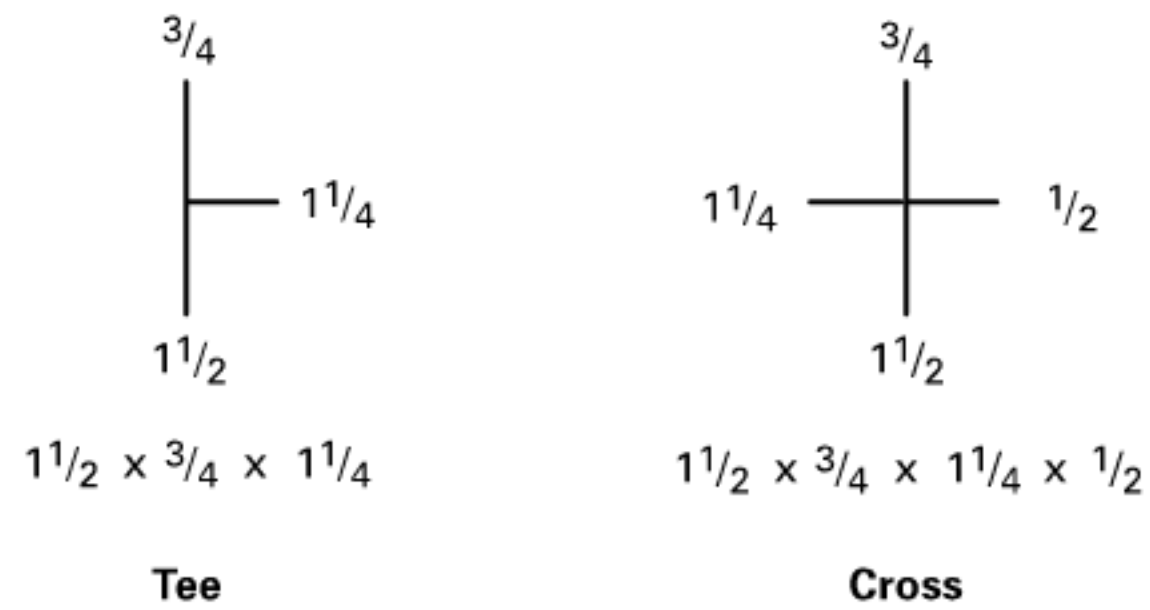

GENERAL NOTE: See para. 3.2.

(c) *Product Conformance.* Fittings covered under para. 1.1.1 shall be marked with either the ASTM Fittings Specification material identification (e.g., “WP_____”) or the symbol “B16” to denote conformance to this Standard. Fittings covered under para. 1.1.2 shall be marked with a supplementary suffix as follows:

(1) For ASTM A234, A403, A420, and A815, suffix the material grade with “S58” (see ASTM A960 Supplementary Requirement S58).

(2) For ASTM Fitting Specification B366, suffix the material grade with “SPLD.”

(3) For all ASTM Forging Specifications, suffix “B16” with “SPLD.”

(d) *Class Designation.* 2000, 3000, 6000, or 9000, as applicable. Alternatively, the designation 2M, 3M, 6M, or 9M, as applicable, may be used where M stands for 1000.

(e) *Size.* The nominal pipe size related to the end connections.

4.1.2 Omission of Markings. Where size and shape of fittings do not permit all of the above markings, they may be omitted in the reverse order given above.

5 MATERIAL

(16) 5.1 Standard Materials

Fittings shall be made of materials consisting of forgings, bar, seamless pipe, or seamless tubular products. These materials shall conform to the requirements for the WP seamless construction materials of ASTM Fitting Specifications A234, A403, A420, A815, or B366 or ASTM Forging Specifications A105, A182, A350, B462, or B564. Tees, elbows, and crosses shall not be machined directly from bar stock.

6 DIMENSIONS

6.1 General

Unless otherwise noted, the dimensions without tolerances for socket-welding fittings given in Tables 1, 2, I-1, and I-2 and the dimensions without tolerances for threaded fittings given in Tables 3 through 6 and Tables I-3 through I-6 are nominal values and subject to the designated manufacturing tolerances.

6.2 Socket Fittings

6.2.1 Body Wall Thickness. The body wall thickness of socket-welding fittings shall be equal to or greater than the values, G , shown in Tables 1 and I-1.

6.2.2 Socket Wall Thickness. The socket wall average thickness and minimum thickness shall not be less than the corresponding values, C , shown in Tables 1, 2, I-1, and I-2.

6.2.3 Socket Position. The fixed position for the bottom of the socket with reference to the centerline of the socket-welding fitting shall be maintained as required by the dimension, A , of Tables 1 and I-1. For reducing fittings, see para. 6.5.

6.2.4 Socket Depth. The socket depth shall not be less than the minimum values, J , shown in Tables 1, 2, I-1, and I-2.

6.2.5 Socket Bore. The inside surface of the socket bore shall present a good workmanlike finish that is free of burrs.

6.2.6 Perpendicularity. The end flats of socket-welding fittings shall be at right angles to the socket axis.

6.2.7 Width. The forging radius shall not reduce the width of the flat welding surface to less than the value shown in Figure 2.

6.3 Threaded Fittings

6.3.1 Wall Thickness. The body or end wall thickness of threaded fittings shall be equal to or greater than the minimum values, G , as shown in Tables 3 through 5 or Tables I-3 through I-5.

6.3.2 Internal Threading. All fittings with internal threads shall be threaded with American National Standard Taper Pipe Threads (ASME B1.20.1). Variations in threading shall be limited to one turn large or one turn small from the gaging notch when using working gages. The reference point for gaging is the starting end of the fitting, provided the chamfer does not exceed the major diameter of the internal thread. When a chamfer on the internal thread exceeds

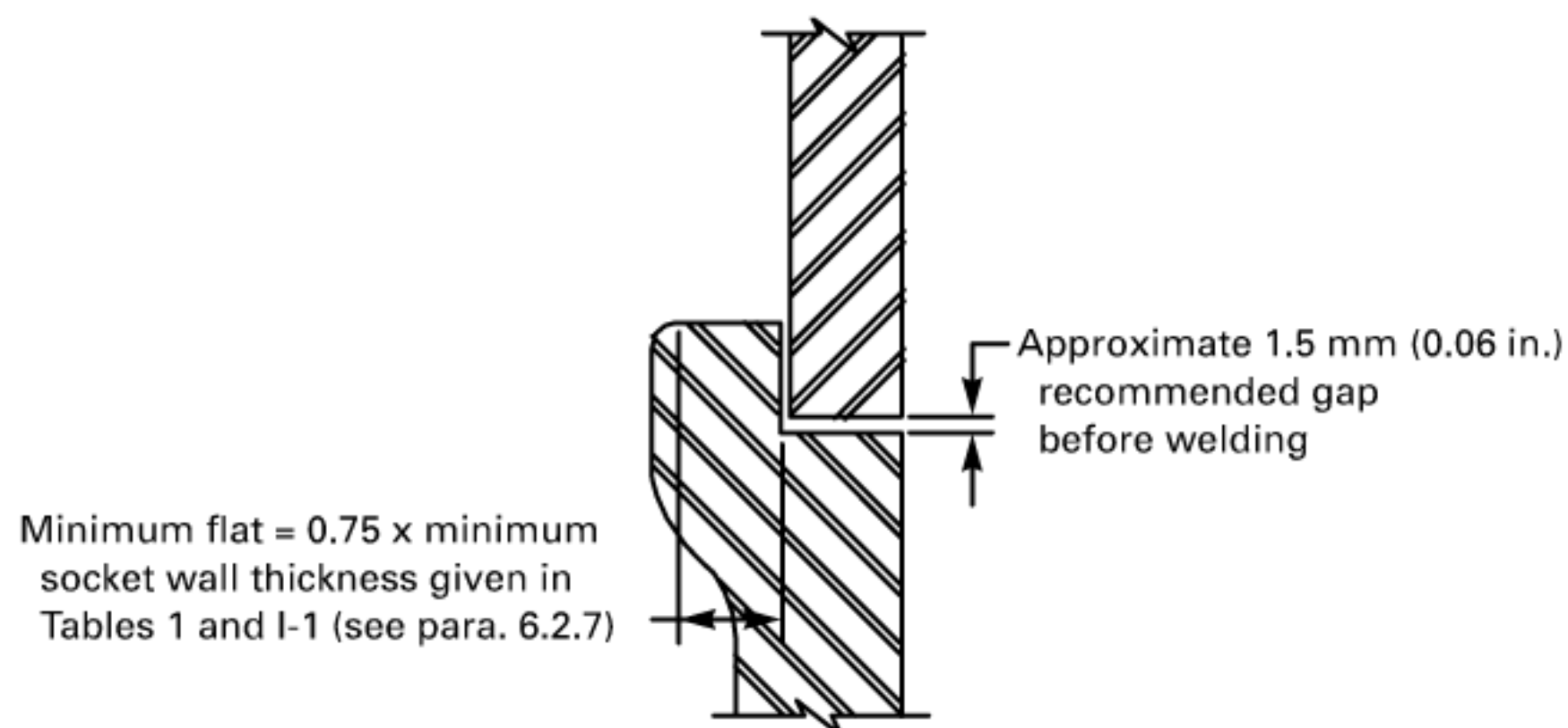
Figure 2 Welding Gap and Minimum Flat Dimensions for Socket-Welding Fittings

this limit, the reference point becomes the last thread scratch on the chamfer cone.

6.3.3 External Threads. All externally threaded fittings shall be threaded with American National Standard Taper Pipe Threads (ASME B1.20.1), and the variation in threading shall be limited to one turn large or one turn small from the gage face of ring when using working gages. The reference point for gaging is the end of the thread, provided the chamfer is not smaller than the minor diameter of the external thread. When a chamfer on the external thread exceeds this limit, the reference point becomes the last thread scratch on the chamfer cone.

6.3.4 Countersink or Chamfer. All internal threads shall be countersunk a distance not less than one-half the pitch of the thread at an angle of approximately 45 deg with the axis of the thread, and all external threads shall be chamfered at an angle of 30 deg to 45 deg from the axis, for easier entrance in making a joint and protection of the thread. Countersinking and chamfering shall be concentric with the threads. The length of threads specified in all tables shall be measured to include the countersink or chamfer.

6.4 Collars

End collars of both socket-welding and threaded fittings shall be such that they overlap the crotch area as illustrated in the sketches in [Tables 1, 3, I-1, and I-3](#).

6.5 Reducing Fittings

Reducing fittings, combination straight and reducing threaded \times threaded, threaded \times socket welding, and socket welding \times socket welding couplings shall have the same center-to-end, center-to-bottom of socket, band diameter, and outside diameters as the uniform size fitting corresponding to the largest size end connection of the reducing fitting.

7 ADDITIONAL TOLERANCES

These are additional tolerances to those listed in [Tables 1, 2, I-1, and I-2](#).

7.1 Concentricity of Bores

The socket and fitting bores shall be concentric within a tolerance of 0.8 mm (0.03 in.) for all sizes. Opposite socket bores shall be concentric within a tolerance of 1.5 mm (0.06 in.) for all sizes.

7.2 Coincidence of Axes

The maximum allowable variation in the alignment of the fitting bore and socket bore axes shall be 1 mm in 200 mm (0.06 in. in 1 ft). The maximum allowable variation in alignment of threads shall be 1 mm in 200 mm (0.06 in. in 1 ft).

8 PROOF TESTING

Proof testing for fittings made to this Standard is not required.

MANDATORY APPENDIX I DIMENSIONS OF FITTINGS IN U.S. CUSTOMARY UNITS

This Mandatory Appendix provides tables for standard inch dimensions of fittings.



Womic
沃米克
www.womicsteel.com

(16)

Table I-1 Socket-Welding Elbows, Tees, and Crosses

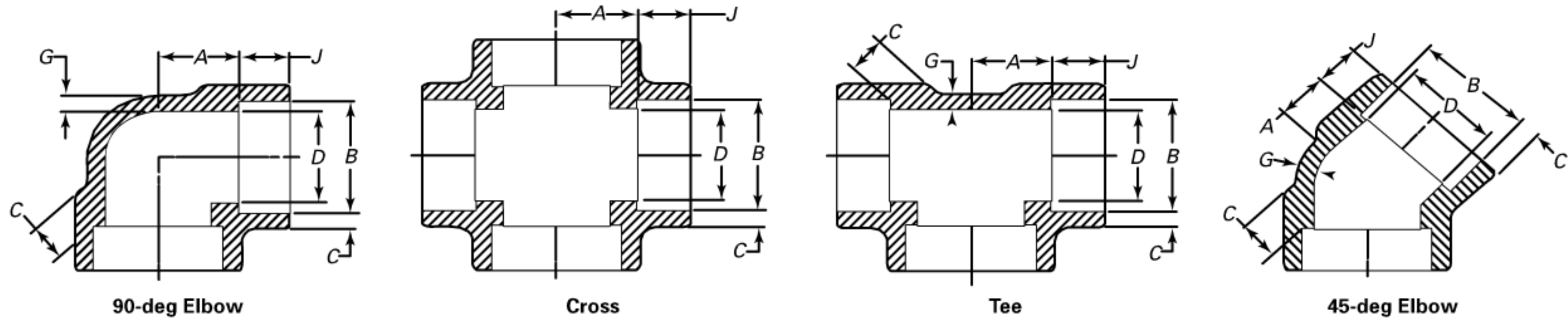

Nominal Pipe Size	Socket Bore Dia., <i>B</i>		Bore Diameter of Fittings, <i>D</i>						Socket Wall Thickness, [Note (1)], <i>C</i>						Body Wall, <i>G</i>			Socket Depth, <i>J</i>	Center-to-Bottom of Socket, <i>A</i>						
			3000		6000		9000		3000		6000		9000		3000	6000	9000		90 Elbows, Tees, and Crosses			45-deg Elbow			Tol ±
			Max.	Min.	Max.	Min.	Max.	Min.	Avg.	Min.	Avg.	Min.	Avg.	Min.	Min.	Min.	Min.		3000	6000	9000	3000	6000	9000	
1/8	0.440	0.420	0.299	0.239	0.189	0.126	0.125	0.125	0.156	0.135	0.095	0.124	...	0.380	0.440	0.440	...	0.310	0.310	...	0.030
1/4	0.575	0.555	0.394	0.334	0.280	0.220	0.149	0.130	0.181	0.158	0.119	0.145	...	0.380	0.440	0.530	...	0.310	0.310	...	0.030
3/8	0.710	0.690	0.523	0.463	0.389	0.329	0.158	0.138	0.198	0.172	0.126	0.158	...	0.380	0.530	0.620	...	0.310	0.440	...	0.060
1/2	0.875	0.855	0.652	0.592	0.494	0.434	0.282	0.222	0.184	0.161	0.235	0.204	0.368	0.322	0.147	0.188	0.294	0.380	0.620	0.750	1.000	0.440	0.500	0.620	0.060
3/4	1.085	1.065	0.854	0.794	0.642	0.582	0.464	0.404	0.193	0.168	0.274	0.238	0.385	0.337	0.154	0.219	0.308	0.500	0.750	0.880	1.120	0.500	0.560	0.750	0.060
1	1.350	1.330	1.079	1.019	0.845	0.785	0.629	0.569	0.224	0.196	0.312	0.273	0.448	0.392	0.179	0.250	0.358	0.500	0.880	1.060	1.250	0.560	0.690	0.810	0.080
1 1/4	1.695	1.675	1.410	1.350	1.190	1.130	0.926	0.866	0.239	0.208	0.312	0.273	0.478	0.418	0.191	0.250	0.382	0.500	1.060	1.250	1.380	0.690	0.810	0.880	0.080
1 1/2	1.935	1.915	1.640	1.580	1.368	1.308	1.130	1.070	0.250	0.218	0.351	0.307	0.500	0.438	0.200	0.281	0.400	0.500	1.250	1.500	1.500	0.810	1.000	1.000	0.080
2	2.426	2.406	2.097	2.037	1.717	1.657	1.533	1.473	0.273	0.238	0.430	0.374	0.545	0.477	0.218	0.344	0.436	0.620	1.500	1.620	2.120	1.000	1.120	1.120	0.080
2 1/2	2.931	2.906	2.529	2.409	0.345	0.302	0.276	0.620	1.620	1.120	0.100
3	3.560	3.535	3.128	3.008	0.375	0.327	0.300	0.620	2.250	1.250	0.100
4	4.570	4.545	4.086	3.966	0.421	0.368	0.337	0.750	2.620	1.620	0.100

GENERAL NOTE: Dimensions are in inches.

NOTE: (1) Average of socket wall thickness around periphery shall not be less than listed values. The minimum values are permitted in localized areas.

(16)

Table I-2 Socket-Welding Couplings, Bosses, Caps, and Couplets

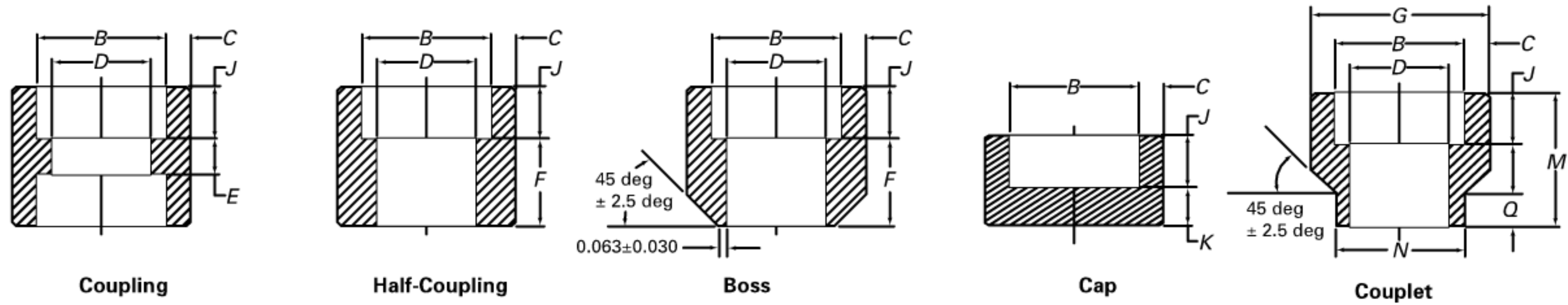

Nominal Pipe Size	Socket Bore Dia., B		Bore Diameter of Fittings, D						Socket Wall Thickness, [Note (1)], C						Outside Dia. Couplet, G		Socket Depth, J	Laying Lgth., E	Laying Lgth., F	End Wall Thickness, K			End to End Couplet, M	Weld Ring Diameter, N	Weld Ring Length, Q								
			3000		6000		9000		3000		6000		9000		3000	6000				9000	Tol.	Tol.			Tol.	3000/6000	Tol.						
	Max.	Min.	Max.	Min.	Max.	Min.	Max.	Min.	Avg.	Min.	Avg.	Min.	Avg.	Min.	Avg.	Min.	±	Min.	±	±	Min.	Min.	Min.	±	±	±	±						
1/8	0.440	0.420	0.299	0.239	0.189	0.126	0.125	0.125	0.156	0.135	+0.06/-0.00	0.38	0.25	0.06	0.62	0.03	0.19	0.25
1/4	0.575	0.555	0.394	0.334	0.280	0.220	3.78	0.130	0.181	0.158	0.94	1.00	+0.06/-0.00	0.38	0.25	0.06	0.62	0.03	0.19	0.25	...	1.19	+0.030/-0.000	0.688	+0.060/-0.000	0.375	0.03		
3/8	0.710	0.690	0.523	0.463	0.389	0.329	0.158	0.138	0.198	0.172	1.06	1.25	+0.06/-0.00	0.38	0.25	0.12	0.69	0.06	0.19	0.25	...	1.19	+0.030/-0.000	0.813	+0.060/-0.000	0.375	0.03		
1/2	0.875	0.855	0.652	0.592	0.494	0.434	0.282	0.222	0.184	0.161	0.235	0.204	0.368	0.322	1.31	1.50	+0.06/-0.00	0.38	0.38	0.12	0.88	0.06	0.25	0.31	0.44	1.31	+0.030/-0.000	0.938	+0.060/-0.000	0.375	0.03		
3/4	1.085	1.065	0.854	0.794	0.642	0.582	0.464	0.404	0.193	0.168	0.274	0.238	0.385	0.337	1.50	1.75	+0.06/-0.00	0.50	0.38	0.12	0.94	0.06	0.25	0.31	0.50	1.38	+0.030/-0.000	1.063	+0.060/-0.000	0.375	0.03		
1	1.350	1.330	1.079	1.019	0.845	0.785	0.629	0.569	0.224	0.196	0.312	0.273	0.448	0.392	1.81	2.25	+0.06/-0.00	0.50	0.50	0.16	1.12	0.08	0.38	0.44	0.56	1.69	+0.030/-0.000	1.313	+0.060/-0.000	0.375	0.03		
1 1/4	1.695	1.675	1.410	1.350	1.190	1.130	0.926	0.866	0.239	0.208	0.312	0.273	0.478	0.418	2.19	2.50	+0.06/-0.00	0.50	0.50	0.16	1.19	0.08	0.38	0.44	0.56	1.88	+0.030/-0.000	1.688	+0.060/-0.000	0.375	0.03		
1 1/2	1.935	1.915	1.640	1.580	1.368	1.308	1.130	1.070	0.250	0.218	0.351	0.307	0.500	0.438	2.50	3.00	+0.06/-0.00	0.50	0.50	0.16	1.25	0.08	0.44	0.50	0.62	2.00	+0.030/-0.000	1.938	+0.060/-0.000	0.375	0.03		
2	2.426	2.406	2.097	2.037	1.717	1.657	1.533	1.473	0.273	0.238	0.430	0.374	0.545	0.477	3.13	3.63	+0.06/-0.00	0.62	0.75	0.16	1.62	0.08	0.50	0.62	0.75	2.25	+0.060/-0.000	2.438	+0.060/-0.000	0.375	0.03		
2 1/2	2.931	2.906	2.529	2.409	0.345	0.302	3.63	4.25	+0.06/-0.00	0.62	0.75	0.20	1.69	0.10	0.62	0.75	...	2.50	+0.060/-0.000	2.875	+0.060/-0.000	0.375	0.03		
3	3.560	3.535	3.128	3.008	0.375	0.327	4.38	5.00	+0.06/-0.00	0.62	0.75	0.20	1.75	0.10	0.75	0.88	...	2.75	+0.060/-0.000	3.500	+0.060/-0.000	0.375	0.03		
4	4.570	4.545	4.086	3.966	0.421	0.368	5.56	6.25	+0.06/-0.00	0.75	0.75	0.20	1.88	0.10	0.88	1.12	...	3.00	+0.060/-0.000	4.500	+0.060/-0.000	0.375	0.03		

GENERAL NOTE: Dimensions are in inches.

NOTE: (1) Average of socket wall thickness around periphery shall not be less than listed values. The minimum values are permitted in localized areas.

(16)

Table I-3 Threaded Elbows, Tees, and Crosses

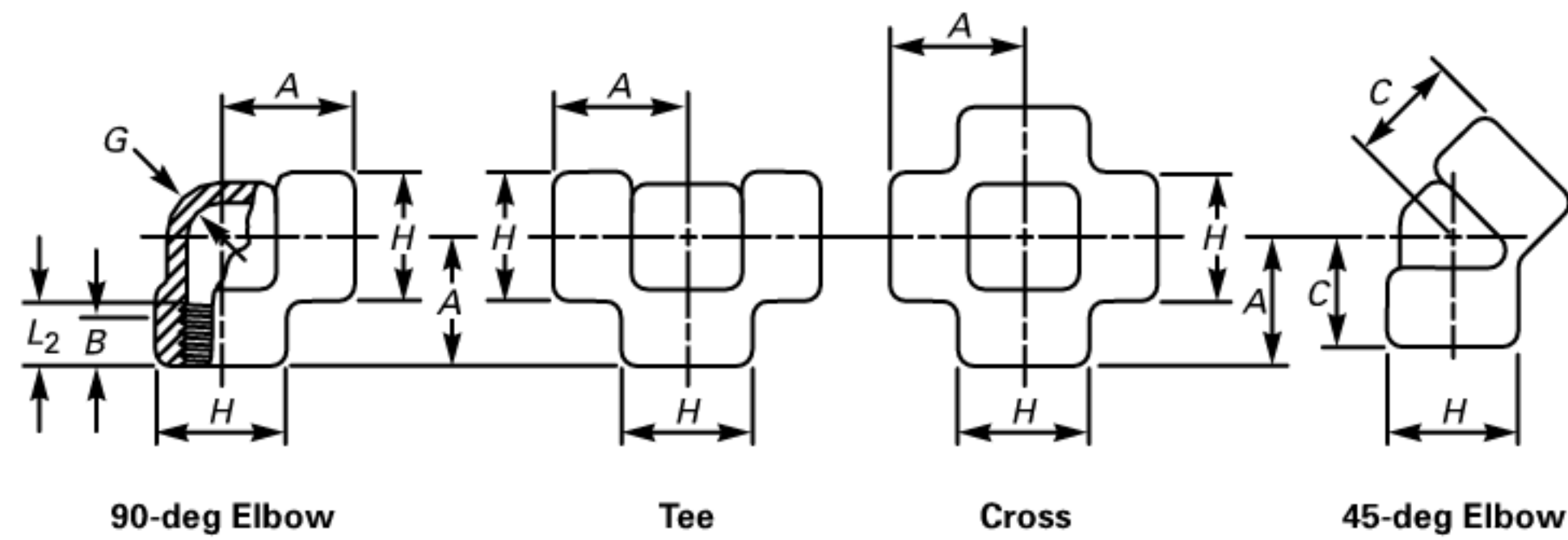

Nominal Pipe Size	Center-to-End Elbows, Tees, and Crosses, <i>A</i>			Center-to-End 45-deg Elbow, <i>C</i>			Outside Diameter of Band, <i>H</i>			Minimum Wall Thickness, <i>G</i>			Minimum Length of Thread [Note (1)]	
	2000	3000	6000	2000	3000	6000	2000	3000	6000	2000	3000	6000	<i>B</i>	<i>L₂</i>
1/8	0.81	0.81	0.97	0.69	0.69	0.75	0.88	0.88	1.00	0.125	0.125	0.250	0.25	0.2639
1/4	0.81	0.97	1.12	0.69	0.75	0.88	0.88	1.00	1.31	0.125	0.130	0.260	0.32	0.4018
3/8	0.97	1.12	1.31	0.75	0.88	1.00	1.00	1.31	1.50	0.125	0.138	0.275	0.36	0.4078
1/2	1.12	1.31	1.50	0.88	1.00	1.12	1.31	1.50	1.81	0.125	0.161	0.321	0.43	0.5337
3/4	1.31	1.50	1.75	1.00	1.12	1.31	1.50	1.81	2.19	0.125	0.170	0.336	0.50	0.5457
1	1.50	1.75	2.00	1.12	1.31	1.38	1.81	2.19	2.44	0.145	0.196	0.391	0.58	0.6828
1 1/4	1.75	2.00	2.38	1.31	1.38	1.69	2.19	2.44	2.97	0.153	0.208	0.417	0.67	0.7068
1 1/2	2.00	2.38	2.50	1.38	1.69	1.72	2.44	2.97	3.31	0.158	0.219	0.436	0.70	0.7235
2	2.38	2.50	3.25	1.69	1.72	2.06	2.97	3.31	4.00	0.168	0.281	0.476	0.75	0.7565
2 1/2	3.00	3.25	3.75	2.06	2.06	2.50	3.62	4.00	4.75	0.221	0.301	0.602	0.93	1.1380
3	3.38	3.75	4.19	2.50	2.50	3.12	4.31	4.75	5.75	0.236	0.348	0.655	1.02	1.2000
4	4.19	4.50	4.50	3.12	3.12	3.12	5.75	6.00	6.00	0.258	0.440	0.735	1.09	1.3000

GENERAL NOTE: Dimensions are in inches.

NOTE: (1) Dimension *B* is minimum length of perfect thread. The length of useful thread (*B* plus threads with fully formed roots and flat crests) shall not be less than *L₂* (effective length of external thread) required by American National Standard for Pipe Threads (ASME B1.20.1; see para. 6.3).

(16)

Table I-4 Threaded Street Elbows

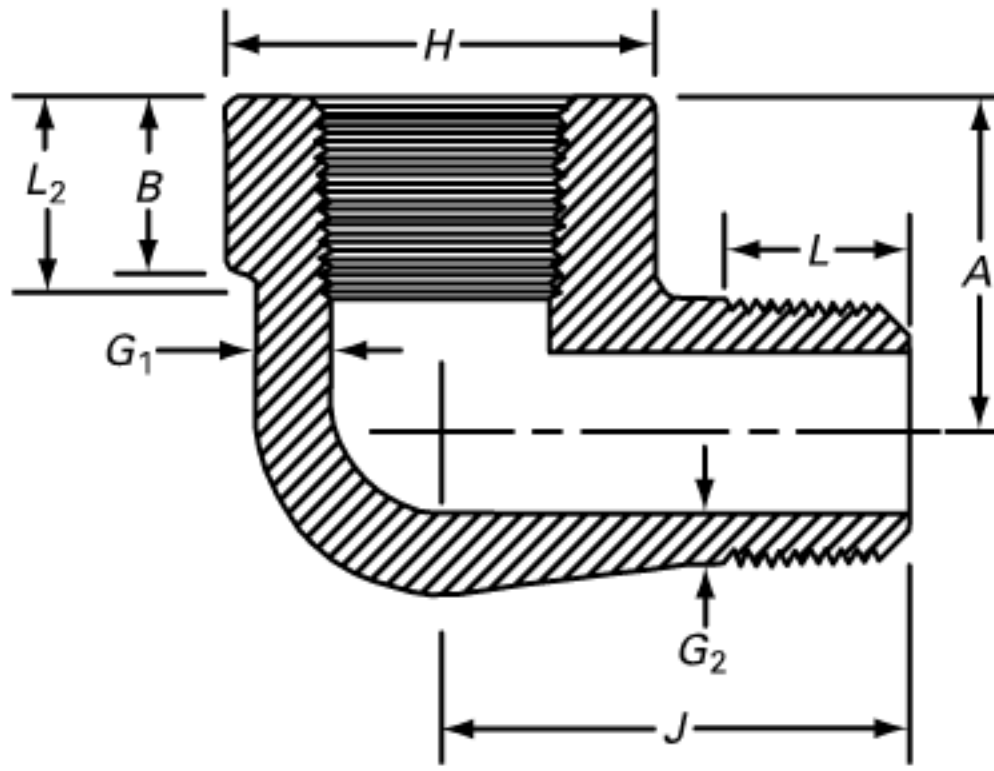

Nominal Pipe Size, NPS	Center-to-Female End Street Ells, A [Note (1)]		Center-to-Male End Street Ells, J		Outside Diameter of Band, H [Note (2)]		Minimum Wall Thickness, G_1		Minimum Wall Thickness, G_2 [Note (3)]		Minimum Length Internal Thread [Note (4)]		Minimum Length Male Thread, L
	Class Designation		Class Designation		Class Designation		Class Designation		Class Designation		B	L_2	
	3000	6000	3000	6000	3000	6000	3000	6000	3000	6000			
1/8	0.75	0.88	1.00	1.25	0.75	1.00	0.125	0.200	0.108	0.166	0.25	0.2639	0.38
1/4	0.88	1.00	1.25	1.50	1.00	1.25	0.130	0.223	0.127	0.208	0.32	0.4018	0.44
3/8	1.00	1.12	1.50	1.62	1.25	1.50	0.138	0.275	0.138	0.220	0.36	0.4078	0.50
1/2	1.12	1.38	1.62	1.88	1.50	1.75	0.161	0.321	0.164	0.257	0.43	0.5337	0.56
3/4	1.38	1.75	1.88	2.25	1.75	2.00	0.170	0.336	0.192	0.270	0.50	0.5457	0.62
1	1.75	2.00	2.25	2.62	2.00	2.44	0.196	0.391	0.219	0.313	0.58	0.6828	0.75
1 1/4	2.00	2.12	2.62	2.81	2.44	2.75	0.208	0.417	0.219	0.334	0.67	0.7068	0.81
1 1/2	2.12	2.50	2.81	3.31	2.75	3.31	0.219	0.436	0.246	0.350	0.70	0.7235	0.81
2	2.50	3.25	3.31	4.13	3.31	4.00	0.281	0.476	0.301	0.382	0.75	0.7565	0.88

GENERAL NOTE: Dimensions are in inches.

NOTES:

- (1) Dimension A of Table I-3 for the appropriate fitting size may also be used at the option of the manufacturer.
- (2) Dimension H of Table I-3 for the appropriate fitting size may also be used at the option of the manufacturer.
- (3) Wall thickness before threading.
- (4) Dimension B is minimum length of perfect thread. The length of useful thread (B plus threads with fully formed roots and flat crests) shall not be less than L_2 (effective length of external thread) required by American National Standard for Pipe Threads (ASME B1.20.1; see para. 6.3).

Table I-5 Threaded Couplings, Bosses, Caps, and Couplets

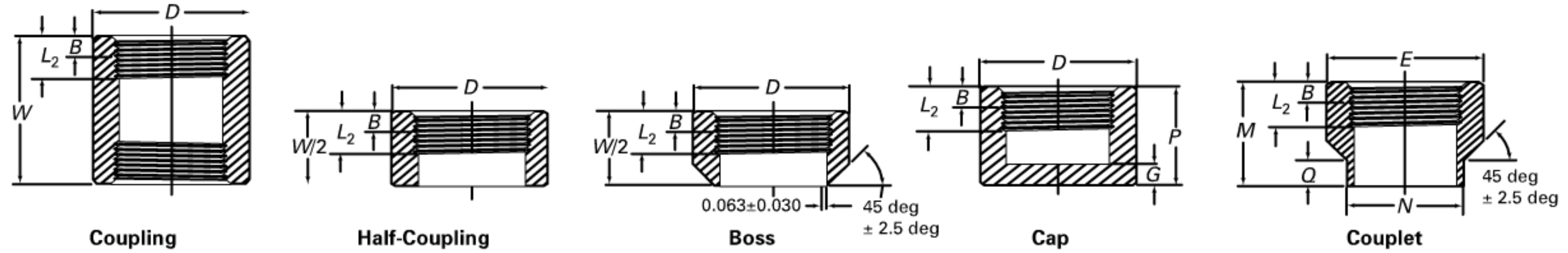

Nominal Pipe Size	Outside Diameter, D		Outside Diameter Couplet, E		Tol.	End-to-End Coupling, W	End-to-End Caps, P		End-to-End Coupling, M	Tol.	Minimum End Wall Thickness, G		Weld Ring Length, Q	Tol.	Weld Ring Diameter, N		Tol.	Minimum Length of Thread [Note (1)]	
	3000	6000	3000	6000			±	3000/6000			3000	6000			3000/6000	±		3000	6000
	$\frac{1}{8}$	0.62	0.88	1.25	0.75	0.88	0.19	0.25	0.25
$\frac{1}{4}$	0.75	1.00	0.928	1.000	+0.06/-0.00	1.38	1.00	1.06	1.188	+0.03/-0.00	0.19	0.25	0.375	0.03	0.688	+0.06/-0.00	0.32	0.4018	
$\frac{3}{8}$	0.88	1.25	1.063	1.250	+0.06/-0.00	1.50	1.00	1.06	1.188	+0.03/-0.00	0.19	0.25	0.375	0.03	0.813	+0.06/-0.00	0.36	0.4078	
$\frac{1}{2}$	1.12	1.50	1.313	1.500	+0.06/-0.00	1.88	1.25	1.31	1.313	+0.03/-0.00	0.25	0.31	0.375	0.03	0.938	+0.06/-0.00	0.43	0.5337	
$\frac{3}{4}$	1.38	1.75	1.500	1.750	+0.06/-0.00	2.00	1.44	1.50	1.375	+0.03/-0.00	0.25	0.31	0.375	0.03	1.063	+0.06/-0.00	0.50	0.5457	
1	1.75	2.25	1.813	2.250	+0.06/-0.00	2.38	1.62	1.69	1.688	+0.03/-0.00	0.38	0.44	0.375	0.03	1.313	+0.06/-0.00	0.58	0.6828	
$1\frac{1}{4}$	2.25	2.50	2.188	2.500	+0.06/-0.00	2.62	1.75	1.81	1.875	+0.03/-0.00	0.38	0.44	0.375	0.03	1.688	+0.06/-0.00	0.67	0.7068	
$1\frac{1}{2}$	2.50	3.00	2.500	3.000	+0.06/-0.00	3.12	1.75	1.88	2.000	+0.03/-0.00	0.44	0.50	0.375	0.03	1.938	+0.06/-0.00	0.70	0.7235	
2	3.00	3.62	3.125	3.625	+0.06/-0.00	3.38	1.88	2.00	2.250	+0.06/-0.00	0.50	0.62	0.375	0.03	2.438	+0.06/-0.00	0.75	0.7565	
$2\frac{1}{2}$	3.62	4.25	3.625	4.250	+0.06/-0.00	3.62	2.38	2.50	2.500	+0.06/-0.00	0.62	0.75	0.375	0.03	2.875	+0.06/-0.00	0.93	1.1380	
3	4.25	5.00	4.375	5.000	+0.06/-0.00	4.25	2.56	2.69	2.750	+0.06/-0.00	0.75	0.88	0.375	0.03	3.500	+0.06/-0.00	1.02	1.2000	
4	5.50	6.25	5.563	6.250	+0.06/-0.00	4.75	2.69	2.94	3.000	+0.06/-0.00	0.88	1.12	0.375	0.03	4.500	+0.06/-0.00	1.09	1.3000	

GENERAL NOTES:

(a) Dimensions are in millimeters.

(b) The wall thickness away from the threaded ends shall meet the minimum wall thickness requirements of Table I-2 for the appropriate NPS and class Designation fitting.

NOTE: (1) Dimension B is minimum length of perfect thread. The length of useful thread (B plus threads with fully formed roots and flat crests) shall be less than L_2 (effective length of external thread) required by American National Standard for Pipe Threads (ASME B1.20.1; see para. 6.3).

Table I-6 Plugs and Bushings

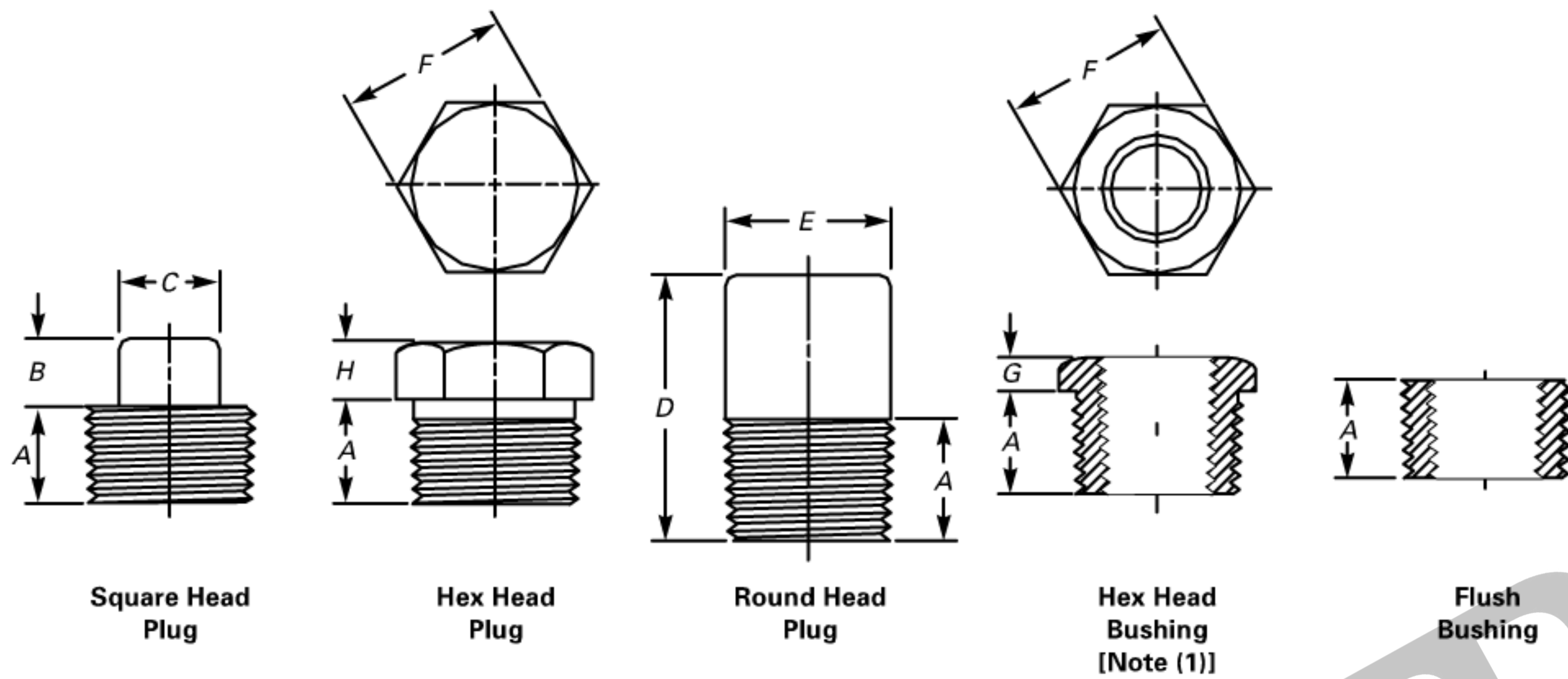

Nominal Pipe Size	Square Head Plugs			Round Head Plugs		Hex Plugs and Bushings		
	Minimum Length, <i>A</i>	Minimum Square Height, <i>B</i>	Minimum Width Flats, <i>C</i> [Note (2)]	Nominal Head Diameter, <i>E</i>	Minimum Length, <i>D</i>	Nominal Width Flats, <i>F</i> [Note (2)]	Minimum Hex Height	
							Bushing, <i>G</i>	Plug, <i>H</i>
1/8	0.38	0.25	0.28	0.41	1.38	0.44	...	0.25
1/4	0.44	0.25	0.38	0.53	1.62	0.62	0.12	0.25
3/8	0.50	0.31	0.44	0.69	1.62	0.69	0.16	0.31
1/2	0.56	0.38	0.56	0.84	1.75	0.88	0.19	0.31
3/4	0.62	0.44	0.62	1.06	1.75	1.06	0.22	0.38
1	0.75	0.50	0.81	1.31	2.00	1.38	0.25	0.38
1 1/4	0.81	0.56	0.94	1.69	2.00	1.75	0.28	0.56
1 1/2	0.81	0.62	1.12	1.91	2.00	2.00	0.31	0.62
2	0.88	0.69	1.31	2.38	2.50	2.50	0.34	0.69
2 1/2	1.06	0.75	1.50	2.88	2.75	3.00	0.38	0.75
3	1.12	0.81	1.69	3.50	2.75	3.50	0.41	0.81
4	1.25	1.00	2.50	4.50	3.00	4.62	0.50	1.00

GENERAL NOTE: Dimensions are in inches.

NOTES:

- (1) *Cautionary Note Regarding Hex Bushings:* Hex head bushings of one-size reduction should not be used in services where they might be subject to harmful loads and forces other than internal pressures.
- (2) Manufacturer's applied tolerance shall ensure dimension will fit U.S. Customary tooling.

MANDATORY APPENDIX II REFERENCES

(16)

The following is a list of publications referenced in this Standard.

ASME B1.20.1, Pipe Threads, General Purpose (Inch)
 ASME B16.34, Valves — Flanged, Threaded, and Welding End
 ASME B36.10M, Welded and Seamless Wrought Steel Pipe
 Publisher: The American Society of Mechanical Engineers (ASME), Two Park Avenue, New York, NY 10016-5990 (www.asme.org)

ASTM A105/A105M-14, Specification for Carbon Steel Forgings for Piping Components
 ASTM A182/A182M-16, Specification for Forged or Rolled Alloy and Stainless Steel Pipe Flanges, Forged Fittings, and Valves and Parts for High-Temperature Service
 ASTM A234/A234M-15, Specification for Piping Fittings of Wrought Carbon Steel and Alloy Steel for Moderate and High Temperature Service
 ASTM A350/A350M-15, Specification for Carbon and Low-Alloy Steel Forgings, Requiring Notch Toughness Testing for Piping Components
 ASTM A403/A403M-16, Specification for Wrought Austenitic Stainless Steel Piping Fittings
 ASTM A420/A420M-16, Specification for Piping Fittings of Wrought Carbon Steel and Alloy Steel for Low-Temperature Service
 ASTM A815/A815M-14^{ε1}, Specification for Wrought Ferritic, Ferritic/Austenitic, and Martensitic Stainless Steel Piping Fittings

ASTM A960/A960M-16, Specification for Common Requirements for Wrought Steel Piping Fittings
 ASTM A961/A961M-16, Standard Specification for Common Requirements for Steel Flanges, Forged Fittings, Valves, and Parts for Piping Applications
 ASTM B366-16^{ε1}, Specification for Factory-Made Wrought Nickel and Nickel Alloy Fittings
 ASTM B462-15, Specification for Forged or Rolled UNS N06030, N06022, N06035, N06200, N06059, N06686, N08020, N08024, N08026, N08367, N10276, N10665, N10675, N10629, N08031, N06045, N06025, and R20033 Alloy Pipe Flanges, Forged Fittings, and Valves and Parts for Corrosive High-Temperature Service
 ASTM B564-15, Specification for Nickel Alloy Forgings
 Publisher: American Society for Testing and Materials (ASTM International), 100 Barr Harbor Drive, P.O. Box C700, West Conshohocken, PA 19428-2959 (www.astm.org)

ISO 9000:2005, Quality management systems — Fundamentals and vocabulary¹
 ISO 9001:2008, Quality management systems — Requirements¹
 ISO 9004:2009, Managing for the sustained success of an organization — A quality management approach¹
 Publisher: International Organization for Standardization (ISO), Central Secretariat, Chemin de Blandonnet 8, Case postale 401, 1214 Vernier, Geneva, Switzerland (www.iso.org)

¹ May also be obtained from the American National Standards Institute (ANSI), 25 West 43rd Street, New York, NY 10036.

NONMANDATORY APPENDIX A QUALITY SYSTEM PROGRAM

The products manufactured in accordance with this Standard shall be produced under a quality system program following the principles of an appropriate standard from the ISO 9000 series.¹ A determination of the need for registration and/or certification of the product manufacturer's quality system program by an independent organization shall be the responsibility of the manufacturer. The detailed documentation demon-

strating program compliance shall be available to the purchaser at the manufacturer's facility. A written summary description of the program utilized by the product manufacturer shall be available to the purchaser upon request. The product manufacturer is defined as the entity whose name or trademark appears on the product in accordance with the marking or identification requirements of this Standard.



¹The series is also available from the American National Standards Institute (ANSI) and the American Society for Quality (ASQ) as American National Standards that are identified by the prefix "Q" replacing the prefix "ISO." Each standard of the series is listed under References in [Mandatory Appendix II](#).

ASME B16.11-2016



Womic
沃米克

www.womicsteel.com

ISBN 978-0-7918-7138-6



9 780791 871386



M 0 1 6 1 6