

**District heating
pipes — Preinsulated
bonded pipe systems
for directly buried
hot water networks
— Pipe assembly of
steel service pipe,
polyurethane thermal
insulation and outer
casing of polyethylene**

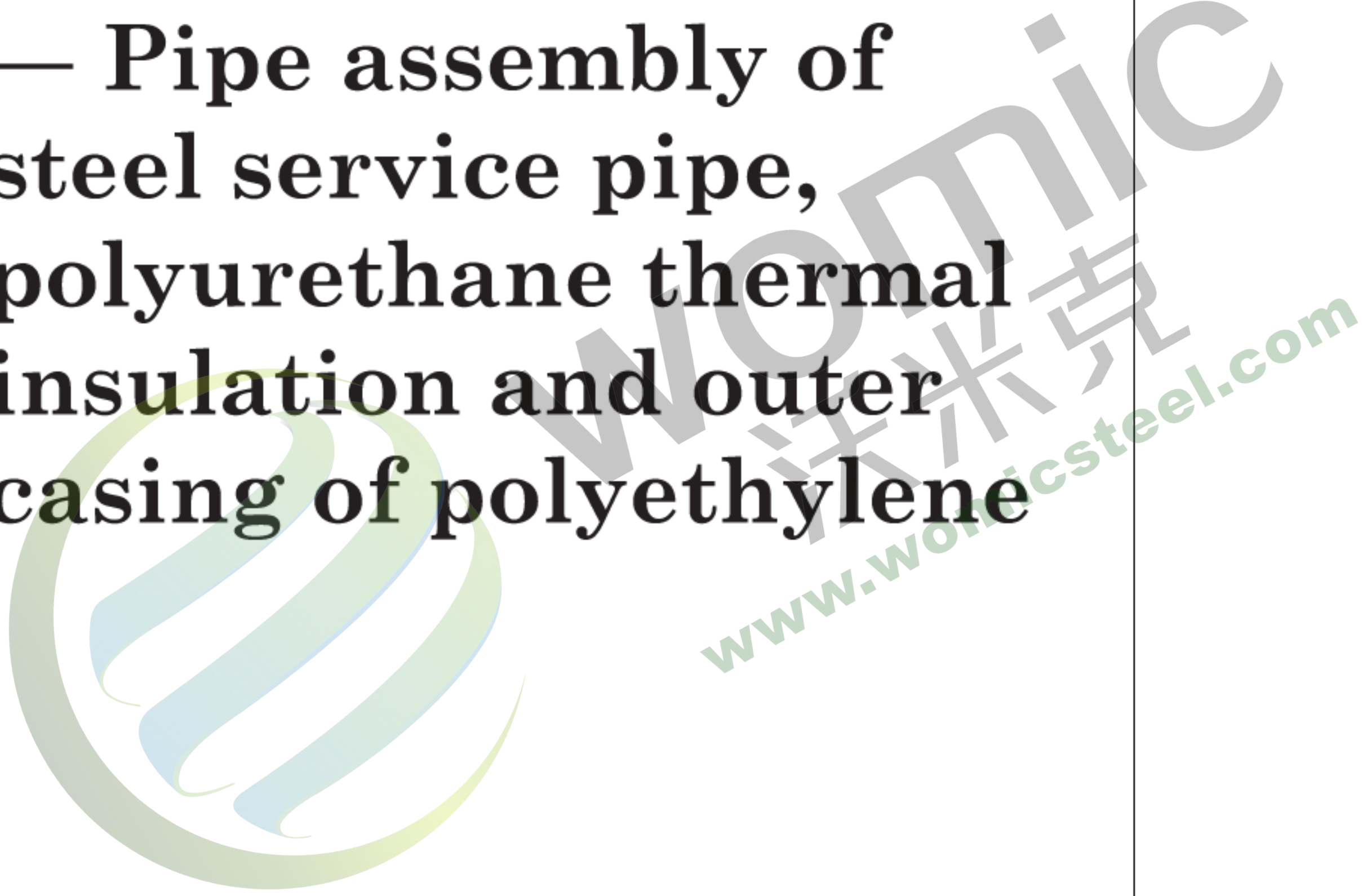

ICS 23.040.10

National foreword

This British Standard is the UK implementation of EN 253:2009+A2:2015. It supersedes BS EN 253:2009+A1:2013 which is withdrawn.

The start and finish of text introduced or altered by amendment is indicated in the text by tags. Tags indicating changes to CEN text carry the number of the CEN amendment. For example, text altered by CEN amendment A1 is indicated by $\boxed{A1}$ $\boxed{A1}$

The UK participation in its preparation was entrusted to Technical Committee RHE/9, Insulated underground pipelines.

A list of organizations represented on this committee can be obtained on request to its secretary.

This publication does not purport to include all the necessary provisions of a contract. Users are responsible for its correct application.

Compliance with a British Standard cannot confer immunity from legal obligations.



WOMIC
沃米克
www.womicsteel.com

This British Standard was published under the authority of the Standards Policy and Strategy Committee on 31 January 2009

© The British Standards Institution 2015.
Published by BSI Standards Limited 2015

Amendments/corrigenda issued since publication

Date	Comments
30 April 2013	Implementation of CEN amendment A1:2013
31 October 2015	Implementation of CEN amendment A2:2015

English Version

District heating pipes - Preinsulated bonded pipe systems for directly buried hot water networks - Pipe assembly of steel service pipe, polyurethane thermal insulation and outer casing of polyethylene

Tuyaux de chauffage urbain - Systèmes bloqués de tuyaux préisolés pour les réseaux d'eau chaude enterrés directement - Tube de service en acier, isolation thermique en polyuréthane et tube de protection en polyéthylène

Fernwärmerohre - Werkmäßig gedämmte Verbundmantelrohrsysteme für direkt erdverlegte Fernwärmenetze - Verbund-Rohrsystem, bestehend aus Stahl-Mediumrohr, Polyurethan-Wärmedämmung und Außenmantel aus Polyethylen

This European Standard was approved by CEN on 14 December 2012 and includes Amendment 2 approved by CEN on 17 July 2015.

CEN members are bound to comply with the CEN/CENELEC Internal Regulations which stipulate the conditions for giving this European Standard the status of a national standard without any alteration. Up-to-date lists and bibliographical references concerning such national standards may be obtained on application to the CEN-CENELEC Management Centre or to any CEN member.

This European Standard exists in three official versions (English, French, German). A version in any other language made by translation under the responsibility of a CEN member into its own language and notified to the CEN-CENELEC Management Centre has the same status as the official versions.

CEN members are the national standards bodies of Austria, Belgium, Bulgaria, Croatia, Cyprus, Czech Republic, Denmark, Estonia, Finland, Former Yugoslav Republic of Macedonia, France, Germany, Greece, Hungary, Iceland, Ireland, Italy, Latvia, Lithuania, Luxembourg, Malta, Netherlands, Norway, Poland, Portugal, Romania, Slovakia, Slovenia, Spain, Sweden, Switzerland, Turkey and United Kingdom.



EUROPEAN COMMITTEE FOR STANDARDIZATION
COMITÉ EUROPÉEN DE NORMALISATION
EUROPÄISCHES KOMITEE FÜR NORMUNG

CEN-CENELEC Management Centre: Avenue Marnix 17, B-1000 Brussels

Contents

Page

European foreword.....	5
Introduction	6
1 Scope.....	7
2 Normative references.....	7
3 Terms and definitions	8
4 Requirements	10
4.1 General.....	10
4.2 Steel service pipe.....	11
4.2.1 Specification.....	11
4.2.2 Diameter.....	11
4.2.3 Wall thickness	12
4.2.4 Surface condition	13
4.3 Casing.....	14
4.3.1 Material properties	14
4.3.2 Casing properties	14
4.4 Polyurethane rigid foam insulation (PUR)	16
4.4.1 Composition	16
4.4.2 Cell structure	16
4.4.3 Compressive strength.....	16
4.4.4 Foam density.....	16
4.4.5 Water absorption at elevated temperature.....	16
4.5 Pipe assembly.....	17
4.5.1 General.....	17
4.5.2 Pipe ends	17
4.5.3 Diameter and wall thickness of the casing.....	17
4.5.4 Centre line deviation.....	18
4.5.5 Expected thermal life and long term temperature resistance.....	18
4.5.6 Thermal conductivity in unaged condition.....	18
4.5.7 Thermal conductivity at artificially aged condition	19
4.5.8 Impact resistance	19
4.5.9 Long term creep resistance and modulus	19
4.5.10 Surface conditions at delivery	19
4.5.11 Measuring wires for surveillance systems.....	19
5 Test methods	19
5.1 General conditions and test specimens	19
5.1.1 General conditions.....	19
5.1.2 Test specimens.....	19
5.2 Casing.....	20
5.2.1 Appearance and surface finish.....	20
5.2.2 Elongation at break	20
5.2.3 Carbon black dispersion, homogeneity.....	21
5.2.4 Stress crack resistance test	21
5.3 Polyurethane rigid foam insulation (PUR)	22
5.3.1 Composition	22
5.3.2 Cell structure	22

5.3.3	Compressive strength	22
5.3.4	5.3.4 Foam density	23
5.3.5	5.3.5 Water absorption.....	23
5.4	Pipe assembly	23
5.4.1	Axial shear strength.....	23
5.4.2	Tangential shear strength	25
5.4.3	Shear strength of the pipe assembly after ageing.....	27
5.4.4	Thermal conductivity in unaged condition.....	27
5.4.5	Thermal conductivity at artificially aged condition	27
5.4.6	Impact resistance.....	27
5.4.7	Long term creep resistance and modulus at 140 °C.....	27
6	Marking	30
6.1	General	30
6.2	Steel service pipe	30
6.3	Casing.....	30
6.4	Pipe assembly	31
Annex A (informative) Relation between actual continuous operating conditions and accelerated ageing test conditions.....		32
Annex B (informative) Calculation of the minimum expected thermal life with operation at various temperatures with respect to PUR foam performance.....		34
Annex C (normative) \square_{A1} Calculated Continuous Operating Temperature (CCOT) \square_{A1}		35
C.1	General	35
C.2	Principle.....	35
C.3	Symbols	35
C.4	Ageing and shear strength determinations	36
C.5	Calculations	36
C.5.1	Determination of the thermal life at different ageing temperatures	36
C.5.2	Adoption to the Arrhenius relation.....	36
C.5.3	Calculated continuous operating temperature, CCOT.....	37
Annex D (informative) Guidelines for inspection and testing.....		38
D.1	General	38
D.2	Manufacturer's type test.....	38
D.3	Manufacturer's quality control.....	38
D.4	External inspection	38
D.5	Manufacturer's responsibility	38
Annex E (informative) Radial creep behaviour of the polyurethane foam (PUR).....		42
Annex F (normative) Thermal conductivity of pre-insulated pipes - Test procedure.....		43
F.1	Scope	43
F.2	Requirements (EN ISO 8497:1996, Clause 5)	43
F.2.1	Test specimen (EN ISO 8497:1996, 5.1).....	43
F.2.2	Operating temperature (EN ISO 8497:1996, 5.2).....	43
F.2.3	Types of apparatus (EN ISO 8497:1996, 5.5)	43

F.3	Apparatus (EN ISO 8497:1996, Clause 7)	43
F.3.1	Guarded end apparatus	43
F.3.2	Calibrated end apparatus	43
F.3.3	Dimensions (EN ISO 8497:1996, 7.2)	44
F.3.4	Heater pipe surface temperature	44
F.4	Test specimens (EN ISO 8497:1996, Clause 8).....	44
F.4.1	Conditioning (EN ISO 8497:1996, 8.4)	44
F.4.2	Dimension measurement (EN ISO 8497:1996, 8.5)	44
F.4.3	Surface temperature measurement	44
F.4.4	Location of temperature sensors (EN ISO 8497:1996, 8.6).....	44
F.5	Procedure (EN ISO 8497:1996, Clause 9)	44
F.5.1	Test length (EN ISO 8497:1996, 9.1.1)	44
F.5.2	Diameter (EN ISO 8497:1996, 8.5)	44
F.5.3	Thickness of casing	44
F.5.4	Ambient requirements (EN ISO 8497:1996, 9.2)	45
F.5.5	Test pipe temperature (EN ISO 8497:1996, 9.3).....	45
F.5.6	Power supply (EN ISO 8497:1996, 7.9).....	45
F.5.7	Ⓐ₂ Axial heat loss Ⓐ ₂	45
F.5.8	Test period and stability (EN ISO 8497:1996, 9.5.3).....	45
F.6	Calculations (EN ISO 8497:1996, Clause 11).....	45
F.6.1	Thermal conductivity (EN ISO 8497:1996, 3.5).....	45
F.7	Symbols and units (EN ISO 8497:1996 Clause 4).....	46
Annex G (informative) National A-deviations		48
G.1	Swedish national legislative deviations on steel service pipes	48
Annex H (informative) Main changes from the previous edition of EN 253		49
Annex I (informative) Waste treatment and recycling		52
Bibliography		53

European foreword

This document (EN 253:2009+A2:2015) has been prepared by Technical Committee CEN/TC 107 “Prefabricated district heating pipe systems”, the secretariat of which is held by DS.

This European Standard shall be given the status of a national standard, either by publication of an identical text or by endorsement, at the latest by April 2016, and conflicting national standards shall be withdrawn at the latest by April 2016.

Attention is drawn to the possibility that some of the elements of this document may be the subject of patent rights. CEN [and/or CENELEC] shall not be held responsible for identifying any or all such patent rights.

This document includes Amendment 1, approved by CEN on 2012-12-14, and Amendment 2, approved by CEN on 2015-07-17.

The start and finish of text introduced or altered by amendment is indicated in the text by tags $\boxed{A_1}$ $\boxed{A_1}$ and $\boxed{A_2}$ $\boxed{A_2}$.

This document supersedes $\boxed{A_2}$ EN 253:2009+A1:2013 $\boxed{A_2}$.

Annex H provides details of significant technical changes between this European Standard and the previous editions.

According to the CEN-CENELEC Internal Regulations, the national standards organizations of the following countries are bound to implement this European Standard: Austria, Belgium, Bulgaria, Croatia, Cyprus, Czech Republic, Denmark, Estonia, Finland, Former Yugoslav Republic of Macedonia, France, Germany, Greece, Hungary, Iceland, Ireland, Italy, Latvia, Lithuania, Luxembourg, Malta, Netherlands, Norway, Poland, Portugal, Romania, Slovakia, Slovenia, Spain, Sweden, Switzerland, Turkey and the United Kingdom.

Introduction

This specification is part of the standards for bonded systems using polyurethane foam thermal insulation applied to bond to a steel service pipe and a polyethylene casing.

The other standards from CEN/TC 107 covering this subject are:

EN 448, *District heating pipes – Preinsulated bonded pipe systems for directly buried hot water networks – Fitting assemblies of steel service pipes, polyurethane thermal insulation and outer casing of polyethylene;*

EN 488, *District heating pipes – Preinsulated bonded pipe systems for directly buried hot water networks – Steel valve assembly for steel service pipes, polyurethane thermal insulation and outer casing of polyethylene;*

EN 489, *District heating pipes – Preinsulated bonded pipe systems for directly buried hot water networks – Joint assembly for steel service pipes, polyurethane thermal insulation and outer casing of polyethylene;*

EN 13941, *Design and installation of preinsulated bonded pipe systems for district heating;*

EN 14419, *District heating pipes – Preinsulated bonded pipe systems for directly buried hot water networks – Surveillance systems;*

EN 15698-1, *District heating pipes – Preinsulated bonded twin pipe systems for directly buried hot water networks – Part 1: Twin pipe assembly of steel service pipe, polyurethane thermal insulation and outer casing of polyethylene*



WOMIC
沃米克
www.womicsteel.com

1 Scope

This European Standard specifies requirements and test methods for straight lengths of prefabricated thermally insulated pipe-in-pipe assemblies for directly buried hot water networks, comprising a steel service pipe from DN 15 to DN 1200, rigid polyurethane foam insulation and an outer casing of polyethylene. The pipe assembly may also include the following additional elements: measuring wires, spacers and diffusion barriers.

This standard applies only to insulated pipe assemblies, for continuous operation with hot water at various temperatures up to 120 °C and occasionally with a peak temperature up to 140 °C.

The estimation of expected thermal life with continuous operation at various temperatures is outlined in Annex B.

2 Normative references

The following referenced documents are indispensable for the application of this document. For dated references, only the edition cited applies. For undated references, the latest edition of the referenced document (including any amendments) applies.

EN 489, *District heating pipes – Preinsulated bonded pipe systems for directly buried hot water networks – Joint assembly for steel service pipes, polyurethane thermal insulation and outer casing of polyethylene*

EN 728, *Plastics piping and ducting systems – Polyolefin pipes and fittings – Determination of oxidation induction time*

EN 10204, *Metallic products – Types of inspection documents*

EN 10216-2, *Seamless steel tubes for pressure purposes – Technical delivery conditions – Part 2: Non-alloy and alloy steel tubes with specified elevated temperature properties*

EN 10217-1, *Welded steel tubes for pressure purposes – Technical delivery conditions – Part 1: Non-alloy steel tubes with specified room temperature properties*

EN 10217-2, *Welded steel tubes for pressure purposes – Technical delivery conditions – Part 2: Electric welded non-alloy and alloy steel tubes with specified elevated temperature properties*

EN 10217-5, *Welded steel tubes for pressure purposes – Technical delivery conditions – Part 5: Submerged arc welded non-alloy and alloy steel tubes with specified elevated temperature properties*

EN 10220, *Seamless and welded steel tubes – Dimensions and masses per unit length*

EN 13941, *Design and installation of preinsulated bonded pipe systems for district heating*

EN 14419, *District heating pipes – Preinsulated bonded pipe systems for directly buried hot water networks – Surveillance systems*

EN ISO 1133:2005, *Plastics – Determination of the melt mass-flow rate (MFR) and the melt volume-flow rate (MVR) of thermoplastics (ISO 1133:2005)*

EN ISO 2505, *Thermoplastics pipes – Longitudinal reversion – Test methods and parameters (ISO 2505:2005)*

EN ISO 3126, *Plastics piping systems – Plastics components – Determination of dimensions (ISO 3126:2005)*

EN ISO 8497:1996, *Thermal insulation – Determination of steady-state thermal transmission properties of thermal insulation for circular pipes (ISO 8497:1994)*

EN ISO 8501-1:2007, *Preparation of steel substrates before application of paints and related products – Visual assessment of surface cleanliness – Part 1: Rust grades and preparation grades of uncoated steel substrates and of steel substrates after overall removal of previous coatings (ISO 8501-1:2007)*

EN ISO 9080, *Plastics piping and ducting systems – Determination of the long-term hydrostatic strength of thermoplastic materials in pipe form by extrapolation (ISO 9080:2003)*

EN ISO 9692-1, *Welding and allied processes – Recommendations for joint preparation – Part 1: Manual metal-arc welding, gas-shielded metal-arc welding, gas welding, TIG welding and beam welding of steels (ISO 9692-1:2003)*

EN ISO 12162, *Thermoplastics materials for pipes and fittings for pressure applications – Classification and designation – Overall service (design) coefficient (ISO 12162:1995)*

ISO 844, *Rigid cellular plastics – Determination of compression properties*

ISO 3127:1994, *Thermoplastics pipes – Determination of resistance to external blows – Round-the-clock method*

ISO 6964, *Polyolefin pipes and fittings – Determination of carbon black content by calcination and pyrolysis – Test method and basic specification*

ISO 11414:1996, *Plastics pipes and fittings -- Preparation of polyethylene (PE) pipe/pipe or pipe/fitting test piece assemblies by butt fusion*

ISO 13953, *Polyethylene (PE) pipes and fittings – Determination of the tensile strength and failure mode of test pieces from a butt-fused joint*

ISO 16770, *Plastics – Determination of environmental stress cracking (ESC) of polyethylene – Full notch creep test (FNCT)*

3 Terms and definitions

For the purposes of this document, the terms and definitions given in ISO 1133:2005 and the following apply.

3.1 ageing

keeping the service pipe at a certain, elevated temperature for a certain time while the casing is exposed to a temperature of $(23 \pm 2) ^\circ\text{C}$

3.2 artificial ageing

keeping the complete pipe assembly at a certain, elevated temperature for a certain time

3.3 batch

specified quantity of raw material made under the same uniform production conditions in one production run by one manufacturer

3.4

bonded system

service pipe, insulating material and casing which are bonded by the insulating material

3.5

calculated continuous operating temperature

CCOT

temperature for which the thermal life of 30 years can be calculated assuming an Arrhenius relationship between temperature and thermal life

3.6

casing

outer layer made of polyethylene to protect the insulation and the service pipe from ground water, moisture and mechanical damage

3.7

centre line deviation

deviation between the centre line of the service pipe and the centre line of the casing

3.8

continuous temperature

temperature at which the hot water network is designed to operate continuously

3.9

creep

slow progressive strain under the influence of stresses

3.10

density

mass of a body of a material divided by the volume of the body

3.11

diffusion barrier

layer in the pipe assembly of another material than PE, installed between the thermal insulation and the PE casing, with the aim to restrict the diffusion of gases through the casing

3.12

foam density

apparent density of the foam of the insulating layer at any position

3.13

fusion compatibility

ability of two PE materials to be fused together to form a joint which conforms to the performance requirements of this European Standard

3.14

insulation material

material which reduces the heat loss

3.15

Polymeric Methylendiphenyl Diisocyanate-Index

MDI-index

quotient of the actual amount of isocyanate used and the stoichiometrically required amount, multiplied by 100

3.16

peak temperature

highest temperature at which a system is designed to operate occasionally, see Annex B

3.17

physical blowing agent

additive in the mixture of isocyanate and polyole which evaporate without reacting during the polymerisations

3.18

pipe assembly

assembled product, consisting of a service pipe, insulating material and a casing

3.19

polyurethane rigid foam

PUR

material resulting from the chemical reaction of polyisocyanates with hydroxyl containing compounds in the presence of catalysts having mainly closed cell structure

NOTE: The foaming can be assisted by a physical blowing agent

3.20

service pipe

steel pipe that contains the water

3.21

shear strength

ability of the pipe assembly to withstand a shear force acting between the casing and the service pipe

3.22

thermal life

time elapsed before the tangential shear stress at 140 °C falls below 0,13 MPa when exposing the pipe continuously to the ageing temperature

NOTE The limit value for the tangential shear strength, 0,13 MPa, used in the definition of the thermal life is clearly higher than the shear strength level necessary in service. As a consequence the useful service life of the pipe system can be expected to exceed the thermal life value.

3.23

virgin material

material in a form such as granules that has not been subjected to use or processing other than that required for its manufacture and to which no reprocessible or recyclable material has been added.

4 Requirements

4.1 General

Unless otherwise specified, the requirements shall be valid for each single measurement.

For information on suitable guidelines for inspection of manufactured preinsulated pipes see Annex D.

4.2 Steel service pipe

Ⓐ₂

4.2.1 Specification

The technical delivery conditions of the steel service pipe shall be in accordance with Table 1.

Table 1 — Steel service pipe specification

Type of pipe	Diameter	EN standard	Material ^a
Seamless	All	EN 10216-2	P235GH
ERW	≤ 60,3 mm (DN 50)	EN 10217-1	P235TR1 ^b or P235TR2
ERW	All	EN 10217-2	P235GH
SAW	All	EN 10217-5	P235GH

^a Equivalent or higher steel grades according to approved EN standards may be used by agreement.

^b If P235TR1 material is used an impact test at 0 °C according EN 10217-1 as for P235TR2 shall be performed.

For higher steel grades than those given in Table 1 the yield strength is defined in their related standards. If such higher steel grades are used for medium pipes, it shall be verified that all components used in the involved part of the system are compatible to the higher yield strength of the pipes.

NOTE 1 Further information on the required steel grades is given in EN 13941.

All steel pipes and components used for manufacturing of pipe assemblies under the scope of this standard shall as a minimum be delivered *to the manufacturer* with an inspection certificate 3.1 according to EN 10204. The inspection certificate shall on request be passed on to the customer.

In case a material related inspection certificate 3.1 according to EN 10204 is required by the client who orders the preinsulated pipe assemblies, this request shall be given whilst placing the order with the manufacturer of the preinsulated pipe assemblies.

NOTE 2 Any later request for provision of such documentation can be too late and can possibly not be met by the manufacturer, since the manufacturer has to organize the assignment of 3.1 certificates to pipes and part of pipes before starting the production.

A length of pipe shall not include a circular joint. Ⓐ₂

Ⓐ₁

4.2.2 Diameter

The diameter shall be in accordance with Table 2 which is derived from EN 10220.

The tolerances on the outside diameter, D_s , of the steel service pipe at the pipe ends, shall be in accordance with Table 3. Diameter measurements shall be made using a circumferential tape. The diameter shall be calculated as the actual circumference divided by π . Outside diameter, D_s , 168,3 and smaller may be measured using a slide calliper.

NOTE To avoid stresses due to temperature differences and misalignment, the tolerances given in Table 3 are more stringent than the tolerances for D_s given in EN 10216-2, EN 10217-1, EN 10217-2 or EN 10217-5.

The out-of-roundness shall be determined in accordance with EN 10216-2, EN 10217-1, EN 10217-2 or EN 10217-5 and shall be within the limits given in these standards. A_1

4.2.3 Wall thickness

The nominal wall thicknesses, T , and masses shall be in accordance with EN 10220 with a minimum as indicated in Table 2.

Subject to design considerations, cf. EN 13941, other wall thicknesses may be used, but in no case shall these be less than the minima indicated in Table 2.

The tolerance on the actual wall thickness, T , of the steel service pipe shall be in accordance with Table 4.

NOTE To avoid stresses due to temperature differences and misalignment, the tolerances given in Table 4 are more stringent than the tolerances for T given in EN 10216 2, EN 10217-1, EN 10217 2 or EN 10217 5.

Table 2 — Steel service pipe dimensions

Nominal diameter DN	Outside diameter D_s mm	Minimum nominal wall thickness T mm
15	21,3	2,0
20	26,9	2,0
25	33,7	2,3
32	42,4	2,6
40	48,3	2,6
50	60,3	2,9
65	76,1	2,9
80	88,9	3,2
100	114,3	3,6
125	139,7	3,6
150	168,3	4,0
200	219,1	4,5
250	273,0	5,0
300	323,9	5,6
350	355,6	5,6
400	406,4	6,3
450	457,0	6,3
500	508,0	6,3
600	610,0	7,1
700	711,0	8,0
800	813,0	8,8
900	914,0	10,0
1 000	1 016,0	11,0
1 200	1 219,0	12,5

Table 3 — Tolerances on outside diameter D_S at pipe ends

Welded pipe		Seamless pipe	
D_S mm	Tolerance mm	D_S mm	Tolerance mm
$D_S \leq 48,3$	$\pm 0,3$	$D_S \leq 114,3$	$\pm 0,4$
$48,3 < D_S \leq 168,3$	$\pm 0,005 D_S$	$114,3 < D_S \leq 219,1$	$\pm 0,005 D_S$
$168,3 < D_S \leq 323,9$	$\pm 1,0$	$219,1 < D_S \leq 711,0$	$\pm 0,006 D_S$
$323,9 < D_S \leq 1219,0$	$\pm 1,6$		

Table 4 — Tolerances on the actual wall thickness

Welded pipe		Seamless pipe		
T mm	$\pm \Delta T$ mm	T mm	$+\Delta T$ mm	$-\Delta T$ mm
2,0	0,3	2,0	0,3	0,2
2,3	0,3	2,3	0,4	0,2
2,6	0,3	2,6	0,4	0,3
2,9	0,3	2,9	0,4	0,3
3,2	0,3	3,2	0,4	0,4
3,6	0,4	3,6	0,5	0,5
4,0	0,5	4,0	0,5	0,5
4,5	0,5	4,5	0,6	0,6
5,0	0,5	5,0	1,0	0,6
5,6	0,5	5,6	1,1	0,7
6,3	0,5	6,3	1,3	0,9
7,1	0,5	7,1	1,4	1,1
8,0	0,5	8,0	1,4	1,1
8,8	0,5	8,8	1,4	1,1
10,0	0,5	10,0	1,4	1,1
11,0	0,5	11,0	1,4	1,1
12,5	0,5	12,5	1,4	1,1

4.2.4 Surface condition

In order to ensure proper bonding between the steel service pipe and the PUR-foam insulation, the following procedure shall be followed:

Prior to insulation, the outer surface of the pipe shall be cleaned so that it is free from rust, mill scale, oil, grease, dust, paint, moisture and other contaminants.

Before cleaning the pipe, the outer surface of the pipe shall comply with rust grade A, B or C according to EN ISO 8501-1:2007, without pitting.

4.3 Casing

4.3.1 Material properties

4.3.1.1 Material composition

The casing may be a separately manufactured pipe or be applied directly onto the insulation by extrusion.

The pipe material shall be black coloured PE virgin or rework material containing only those anti-oxidants, UV-stabilizers and carbon black necessary for the manufacture and end use of pipes to this specification. The black coloured PE material to be extruded shall be tested in accordance with EN ISO 9080 and classified at least a PE 80 material in accordance with EN ISO 12162.

The carbon black content shall, when tested in accordance with ISO 6964, be $(2,5 \pm 0,5)$ % by mass.

The carbon black shall be finely dispersed in the material. When tested in accordance with 5.2.3, the following requirements shall be met:

Carbon black agglomerates, bubbles, voids or foreign matter shall not exceed 100 μm in diameter. No white or black stripes or smears may occur.

4.3.1.2 Melt mass-flow rate

The melt mass-flow rate (MFR), in g/10 min, of black PE materials used for the manufacturing of casings shall lie within $0,2 \leq \text{MFR} \leq 1,4$ g/10 min determined in accordance with EN ISO 1133, condition T (5kg, 190 °C).

Black coloured PE materials conforming to 4.3.1.1, which do not differ more than 0,5 g/10 min in MFR shall be considered fusible to each other.

Casings made of PE materials outside this MFR range of 0,5 g/10 min may be fusion welded provided that the pipe manufacturer has demonstrated fusion compatibility by preparing a butt fusion joint using the parameters as specified in Annex A of ISO 11414:1996. The requirement of fusion compatibility is a ductile failure mode of the joint when tested at 23 °C in accordance with ISO 13953.

4.3.1.3 Thermal stability

The thermal stability is determined by oxygen induction time (OIT) of the black coloured PE material and shall be at least 20 min when tested at 210 °C according to EN 728.

4.3.1.4 Use of rework material

Only clean, not degraded, rework material, generated from the manufacturer's own production of pipes, shall be used.

4.3.2 Casing properties

4.3.2.1 Nominal outside diameter

The nominal outside diameter of the casing should be selected from Table 5.

The actual outside diameter shall be measured in accordance with EN ISO 3126.

4.3.2.2 Wall thickness

The wall thickness of the casing shall be in accordance with Table 5.

The actual wall thickness shall be measured in accordance with EN ISO 3126.

Table 5 — Casing dimensions

Nominal outside diameter D_c mm	Minimum wall thickness e_{min} mm
75	3,0
90	3,0
110	3,0
125	3,0
140	3,0
160	3,0
180	3,0
200	3,2
225	3,4
250	3,6
280	3,9
315	4,1
355	4,5
400	4,8
450	5,2
500	5,6
560	6,0
630	6,6
710	7,2
800	7,9
900	8,7
1 000	9,4
1 100	10,2
1 200	11,0
1 400	12,5

4.3.2.3 Appearance, surface finish, pipe ends

The internal and external surfaces¹⁾ of the casing pipe shall be clean and free from such grooving or other defects that might impair its functional properties (see 5.2.1).

The pipe ends shall be cleanly cut and shall be square within 2,5° with the axis of the pipe.

¹⁾ Surface treatment to improve the shear strength between the PUR foam and casing pipe is permissible provided that the treated pipe still complies with the specification.

4.3.2.4 Elongation at break

The elongation at break determined in accordance with 5.2.2 shall not be less than 350 %.

The test is to be applied only on casings that are produced partly or fully from rework material.

4.3.2.5 Heat reversion

When tested in accordance with EN ISO 2505, the longitudinal length at any position on the pipe shall not change by more than 3 %. On inspection after testing, the pipe shall not show any faults, cracks, cavities or blisters.

4.3.2.6 Stress crack resistance

When tested in accordance with 5.2.4, the time to failure shall not be less than 300 h.

4.4 Polyurethane rigid foam insulation (PUR)

4.4.1 Composition

The manufacturer of the pipe assembly shall be responsible for the choice of raw materials, composition and manufacturing conditions.

The manufacturer shall keep records, documenting the raw materials used, the prescribed mixing ratio and the tests performed.

The records shall demonstrate that the foam from the production of pipe assemblies is of the same composition as the foam sample used for the ageing test in 5.4.3 and meets the requirements of 4.4.

Ⓐ

4.4.2 Cell structure

The PUR-foam shall have a uniform cell structure free from smears. The average cell size of the cells in a radial direction shall be less than 0.5 mm, determined in accordance with 5.3.2.1.

The closed cell content determined in accordance with 5.3.2.2 shall be not less than 88 %.

The average area of voids and bubbles determined on the five cross sections in accordance with 5.3.2.3 shall not constitute more than 5 % of the nominal cross sectional area of the PUR foam. No single void shall leave less than 1/3 of the nominal insulation thickness between the steel service pipe and the casing. Ⓐ

4.4.3 Compressive strength

The compressive strength or the compressive stress at 10 % relative deformation as defined in ISO 844 shall be not less than 0,3 MPa in a radial direction when tested in accordance with 5.3.3.

Ⓐ

4.4.4 Foam density

The density of the foam at any position shall comply with the criteria below when measured in accordance with 5.3.4.

At both pipe ends, all three specimens, shall each have a density of minimum 55 kg/m³.

4.4.5 Water absorption at elevated temperature

When tested in accordance with 5.3.5, the water absorption after 90 min of immersion in boiling water shall not exceed 10 % of the original volume. Ⓐ

4.5 Pipe assembly

4.5.1 General

All requirements are valid including the diffusion barrier, if any.

4.5.2 Pipe ends

Both ends of the service pipe shall be free from insulation for a minimum of 150 mm. The tolerance on the declared value shall be ± 10 mm. Service pipe ends shall be prepared for welding in accordance with EN ISO 9692-1.

4.5.3 Diameter and wall thickness of the casing

The outside diameter of the PE casing shall at any point be between the minimum diameter D_{\min} and the maximum diameter D_{\max} as given in Table 6. The minimum wall thickness of the PE casing, e_{\min} , shall at any point be in accordance with Table 6. The measured values for the outside diameter and wall thickness shall be rounded off to the next higher 0,1 mm.

Table 6 — Casing dimensions of the pipe assembly

Nominal outside diameter D_c mm	Minimum outside diameter D_{\min} mm	Maximum outside diameter D_{\max} mm	Minimum wall thickness e_{\min} mm
75	75	79	3,0
90	90	95	3,0
110	110	116	3,0
125	125	132	3,0
140	140	147	3,0
160	160	168	3,0
180	180	189	3,0
200	200	206	3,2
225	225	232	3,4
250	250	258	3,6
280	280	289	3,9
315	315	325	4,1
355	355	366	4,5
400	400	412	4,8
450	450	464	5,2
500	500	515	5,6
560	560	577	6,0
630	630	649	6,6
710	710	732	7,2
800	800	824	7,9
900	900	927	8,7
1 000	1 000	1030	9,4
1 100	1 100	1133	10,2
1 200	1 200	1236	11,0
1 400	1 400	1442	12,5

4.5.4 Centre line deviation

The distance between the centre lines of the service pipe and the casing at any point shall not exceed the limits given in Table 7.

Table 7 — Centre line deviation related to the nominal diameters

Nominal outside diameter of PE pipe mm	Maximum centre line deviation mm
75 to 160	3,0
180 to 400	5,0
450 to 630	8,0
710 to 800	10,0
900 to 1400	14,0

4.5.5 Expected thermal life and long term temperature resistance

4.5.5.1 General remarks

For normal applications, the pipe assembly should have a life of at least 30 years at a continuous operating temperature of 120 °C, at least 50 years at a continuous operating temperature of 115 °C and over 50 years at a continuous operating temperature below 115 °C.

Higher continuous operating temperatures can be stated. If so, the calculated continuous operating temperature (CCOT) shall be established in accordance with Annex C.

NOTE The life span of the bonded pipe systems are affected apart from the thermal stress also by oxidative and mechanical processes. The indicated continuous operation temperature considers only the thermal stress.

4.5.5.2 Shear strength

The shear strength shall fulfil the minimum requirements of Table 8 in both unaged and aged condition.

The shear strength in unaged condition shall be tested in either axial direction in accordance with 5.4.1 or in tangential direction in accordance with 5.4.2.

The shear strength in aged condition shall be tested in accordance with 5.4.3.

Table 8 — Shear strength

Test temperature °C	Test clause	τ_{ax} min. MPa	Test clause	τ_{tan} min. MPa
23 ± 2	5.4.1.4	0,12	5.4.2	0,20
140 ± 2	5.4.1.5	0,08	—	—

A₂

4.5.6 Thermal conductivity in unaged condition

When tested in accordance with 5.4.4, the thermal conductivity (λ_{50}) shall not exceed 0,029 W/(m × K). For type test the thermal conductivity shall be reported together with the foam density, cell size, compressive strength and composition of the gas in the cells of the insulation.

4.5.7 Thermal conductivity at artificially aged condition

When aged according to 5.4.5 the test shall be performed in accordance with 5.4.4. For type test, the thermal conductivity shall be reported together with the foam density, cell size, compressive strength and composition of the gas in the cells of the insulation. A_2

4.5.8 Impact resistance

After testing in accordance with 5.4.6, the casing shall have no visible cracks.

4.5.9 Long term creep resistance and modulus

The long term creep resistance value obtained by the test method in 5.4.7 shall be documented by the manufacturer.

4.5.10 Surface conditions at delivery

The surface flattening of the pipe assembly shall not exceed 15 % of the insulation thickness - measured from the original surface.

Scratches in the casing from the handling and the storage shall not exceed 10 % of the original wall thickness of the casing. On casings with a wall thickness exceeding 10 mm scratches shall not be deeper than 1 mm.

4.5.11 Measuring wires for surveillance systems

Measuring wires, if any, shall comply with the requirements of EN 14419.

5 Test methods

5.1 General conditions and test specimens

5.1.1 General conditions

Where test requirements specified in this standard differ from those in other standards referred to, the requirements laid down in this standard shall apply.

All test specimens shall be representative for the production.

All test on the pipe assembly shall include the diffusion barrier, if any, except those which are particularly mentioned to be without.

5.1.2 Test specimens

5.1.2.1 Test specimens shall only be taken from the casing after it has been stored at a temperature of $(23 \pm 2)^\circ\text{C}$ for not less than 16 h, or from the PUR foam and pipe assembly after they have been stored at a temperature of $(23 \pm 2)^\circ\text{C}$ for not less than 72 h. Deviations from these periods are allowed, e.g. for quality control purposes. However, in event of a dispute, the required periods shall be observed.

5.1.2.2 Test specimens to establish foam properties and to determine properties of the pipe assembly shall be taken from pipe assemblies from regular production, but in such a way as to exclude at least 500 mm from the end of the foam. Test specimens to establish foam properties shall be taken from both ends of the pipe assembly.

5.1.2.3 Test specimens may be taken closer to the end of the foam, e.g. for quality control purposes. However, in event of a dispute the result from test specimens taken at least 500 mm from the end of the foam shall apply.

A2

5.1.2.4 When cutting test specimens from the foam to determine cell structure (4.4.2), compressive strength (4.4.3), foam density (4.4.4) and water absorption (4.4.5), the foam adjacent to the service pipe surface and casing surface shall be excluded; a clearance of at least 5 mm and 3 mm respectively shall be allowed.

5.1.2.5 At the locations where test specimens are taken to determine cell structure (4.4.2), compressive strength (4.4.3), foam density (4.4.4) and water absorption (4.4.5), at least 3 test specimens shall be taken, equally distributed around the circumference. **A2**

5.1.2.6 The outside dimensions of test specimens shall be measured by means of a gauge having a square or circular face area of 100 mm² and an applied force of 0,75 N to 1,0 N.

5.2 Casing

5.2.1 Appearance and surface finish

The internal and external surfaces of the pipe shall be visually examined without magnification (see 4.3.2.3).

5.2.2 Elongation at break

The test bars shall be stamped or machined according to Figure 1, type A. Any diffusion barrier shall be cut or machined away from the test bar.

Test bars may be cut in the longitudinal or circumferential direction and shall be equally distributed over the circumference of the pipe in the same cross section.

Depending on the diameter of the pipe, the number of test bars to be cut and tested shall be in accordance with Table 9.

Table 9 — Number of test bars related to the nominal diameters

Nominal outside diameter of PE pipe mm	Number of test bars
75 to 250	5
280 to 400	7
450 to 630	10
710 to 1400	12

Using an ink or wax crayon, the two reference lines shall be drawn equidistant from the ends of the calibrated length of the test bar. See Figure 1.

The test bars shall be tested at (23 ± 2) °C to which temperature the test bars shall be conditioned for not less than 2 h before the testing.

Using a suitable tensile testing machine, the test bars shall be elongated at a speed of (100 ± 10) mm/min until break.

The distance between the reference lines shall be measured after the test and the elongation shall be calculated and expressed in percent of the original distance between the reference lines.

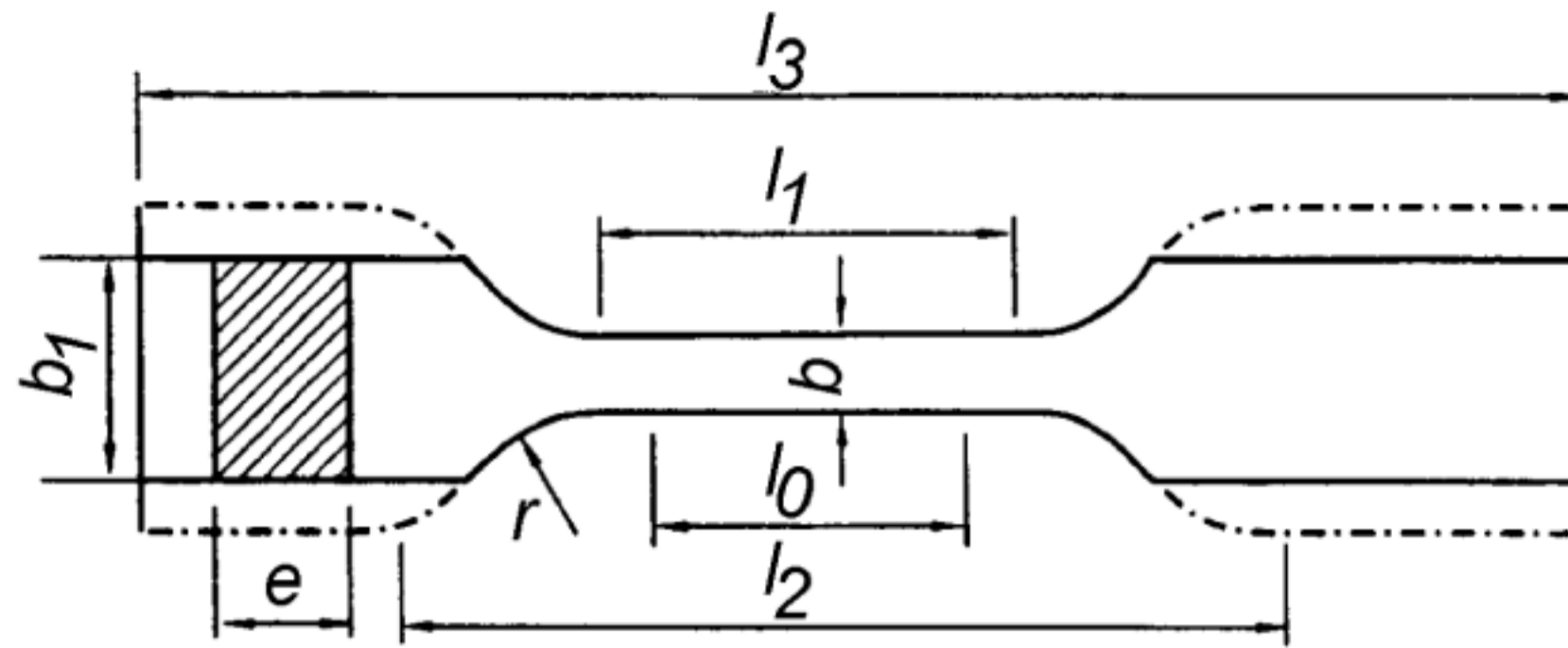

Symbol	Description	Dimensions mm	
		Type A	Type B
l_0	Distance between reference lines	25 ± 1	50 ± 2
l_1	Calibrated length	33 ± 3	60 ± 2
l_3	Total length	115	≥ 150
l_2	Initial distance	80 ± 2	115 ± 2
e	Casing wall thickness	-	-
r	Radius	14 ± 1	60 ± 1
b	Calibrated width	$6 \pm 0,4$	$10 \pm 0,4$
b_1	End part width	>15	>20

Figure 1 — Tensile test bars

5.2.3 Carbon black dispersion, homogeneity

The carbon black dispersion shall be determined by microscopy on microtome slices.

The thickness of the microtome slices shall be approximately 25 μm and the size approximately 15 mm^2 .

At each test, 6 microtome slices shall be cut, equally divided over the same cross section of the casing. By the microscopy, a magnification of 100 times shall be used.

5.2.4 Stress crack resistance test

The test shall be carried out in accordance with ISO 16770 with the following exceptions.

The test samples shall be cut from the same circumference of the casing. They shall be cut in the axial direction of the pipe.

The sample form may be dumbbells according to Figure 1, type B, or they may be cut with parallel sides and 10 mm wide. The thickness shall be the casing wall thickness. The samples may be produced either by milling, cutting or punching.

The length of the samples shall be sufficient to leave four times the wall thickness between the clamps.

In the middle of the test samples a notch shall be produced perpendicular to the axis in all four sides in the same cross section.

Due to casing rounding the produced notch may have an uneven depth around the sample, but the notch depth and position shall be chosen such that no part of the sample cross section is left unnotched.

The number of samples shall be four.

The test solution shall be water containing 2,0 % tenside.

The tenside shall be nonylphenol polyglycol-ether with the same effect as the tenside with the trade name 'Arkopal N 100®'.

The temperature shall be 80 °C.

The test load shall be 4,0 N/mm².

5.3 Polyurethane rigid foam insulation (PUR)

5.3.1 Composition

The MDI-index shall be calculated from the manufacturer's production data and be recorded.

Ⓐ

5.3.2 Cell structure

5.3.2.1 The size of the cells shall be determined over a length of 10 mm measured in a radial direction with the centre of the 10 mm measurement coinciding with the centre point of the applied insulation.

The size of the cells shall be the quotient of the test length and the number of cells counted along the radial line of test length selected and shall be determined as an average value of measurements on 3 specimens.

5.3.2.2 The ratio of open to closed cells shall be determined in accordance with ISO 4590:2002 (method 1).

Deviating from the procedure described in ISO 4590, the test specimen shall be a cube with an edge of 25 mm. If this size of cube cannot be cut from the insulation in accordance with 5.1.2, the dimensions shall be 25 mm × 25 mm × *t*, where *t* is the maximum radial thickness.

5.3.2.3 Voids and bubbles shall be determined on cross sections of the insulation material.

Minimum 1,5 m from the foam end, 5 circumferential cuts through the casing and the insulation shall be made with a distance of 100 mm including a total of 400 mm casing.

The four 100 mm rings of casing and insulation shall be removed one by one and the five cross section surfaces inspected for voids and bubbles.

All voids larger than 6 mm in any direction shall be measured in 2 directions perpendicular to each other, and the product of the 2 measurements shall be defined as the area of the void.

Voids smaller than 6 mm shall be neglected.

The addition of the area of all the voids shall be expressed as a percentage of the total inspected area.

5.3.3 Compressive strength

The compressive strength in a radial direction shall be tested in accordance with ISO 844.

Test specimens shall be taken in accordance with 5.1.2. The test specimen shall be 30 mm × 30 mm × *t* or a cylinder with a diameter of 30 mm and a length of *t*, where *t* is the maximum obtainable dimension in the radial direction but not exceeding 20 mm.

The test result shall be determined as an average value of 3 measurements.

For the Manufacturer's quality control other qualified - fully documented correlated method may be used.

5.3.4 Foam density

The foam density shall be measured in accordance with ISO 845.

Test specimens shall be taken from both pipe ends in sets of 3 in accordance with 5.1.2. Each test specimen shall be 30 mm × 30 mm × t where t is the maximum obtainable thickness but not exceeding 30 mm. Alternatively, test specimens shall be cylindrical, 30 mm long in the axial direction of the pipe and of diameter d where d is the maximum obtainable diameter but not exceeding 30 mm.

For the Manufacturer's quality control other qualified - fully documented correlated method can be used.

5.3.5 Water absorption

The test shall be performed on a cube with an edge of 25 mm, or a cylinder of length 25 mm in the axial direction of the pipe and a diameter of 25 mm. The mass (m_0) of the test specimen shall be determined to an accuracy of 0,01 g and the volume (V_0) shall be determined to an accuracy of 0,1 ml. The specimen shall be immersed in boiling water for 90 min. After this, it shall be immersed immediately in water at (23 ± 2) °C for 1 h. Surface water shall be removed from the specimen by successively placing each side of the specimen for 3 s to 5 s on a tissue (e.g. Kleenex® No 7101 or similar). The mass (m_1) shall then be determined to an accuracy of 0,01 g.

The water absorption percentage shall be calculated from:

$$\frac{m_1 - m_0}{V_0 \times \rho} \times 100 \%$$

where

m_0 is the mass of the test specimen before testing, in g;

m_1 is the mass of the test specimen after the test period, in g;

ρ is the density of the water, in g/ml;

V_0 is the original volume of the test specimen, in ml.

The test result shall be determined as an average value of measurements come out on 3 specimens. A_2

5.4 Pipe assembly

5.4.1 Axial shear strength

5.4.1.1 Test specimen

The test specimen shall be a length of pipe assembly equal to 2,5 times the thickness of the insulation but not less than 200 mm. The test specimen shall be cut square to the axis of the pipe and be taken in accordance with 5.1.2.2 and in the middle of the pipe.

5.4.1.2 Test procedure

An axial force shall be applied. The speed of the testing machine shall be 5 mm/min. The axial force shall be recorded and the shear strength calculated. This test may be performed with the axis of the pipe vertical or horizontal (see Figure 2). The dead weight of the service pipe shall be taken into consideration when the axis is vertical.

The test result shall be determined as an average value of 3 measurements.

5.4.1.3 Calculation of shear strength

The shear strength is calculated from the following formula:

$$\tau_{ax} = \frac{F_{ax}}{L \times D_s \times \pi} \quad (2)$$

where

τ_{ax} = axial shear strength, in MPa;

F_{ax} = axial force, in N;

L = length of specimen, in mm;

D_s = outside diameter of the service pipe, in mm.

5.4.1.4 Axial shear strength at 23 °C

The test shall be carried out in accordance with 5.4.1.1 to 5.4.1.3, with the entire test specimen kept at a temperature of (23 ± 2) °C.

5.4.1.5 Axial shear strength at 140 °C

The test shall be carried out in accordance with 5.4.1.1 to 5.4.1.3, with the service pipe kept at a temperature of (140 ± 2) °C. This temperature shall be reached within 30 min and maintained for 30 min before applying the force.



WOMIC
沃米克
www.womicsteel.com

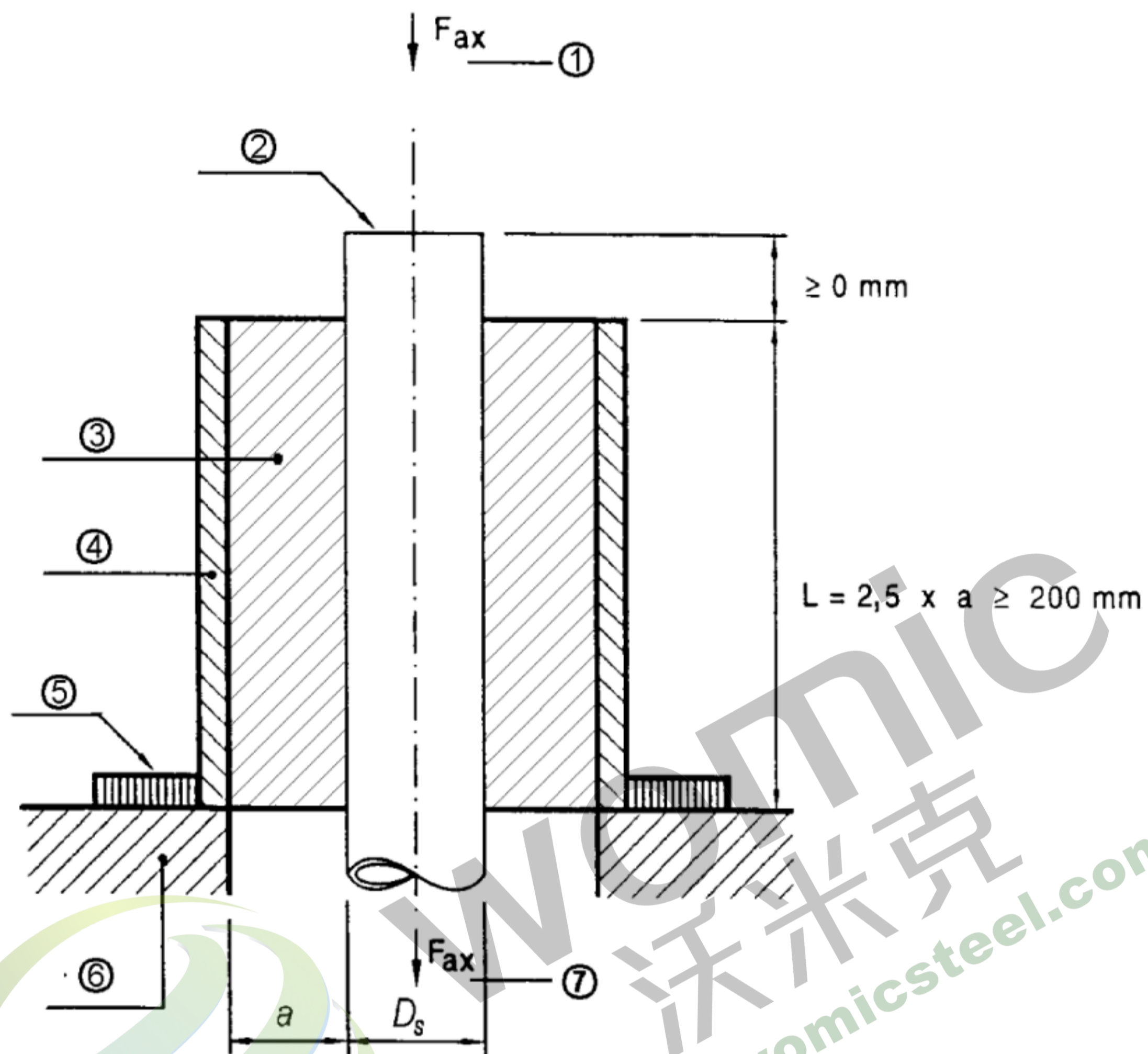

Key

- | | |
|-----------------------|------------------------------|
| 1 Applied load | 5 Guide ring |
| 2 Service pipe | 6 Base plate of test machine |
| 3 PUR foam insulation | 7 Alternatively applied load |
| 4 Casing | |

Figure 2 — Axial shear test arrangement

5.4.2 Tangential shear strength

5.4.2.1 Test specimen

The test specimen shall be a length of pipe assembly equal to 0,75 times the diameter of the service pipe, but not less than 100 mm.

5.4.2.2 Test procedure

The tangential force shall be exerted by two levers which are symmetrically attached to the casing by means of a carrier clamp, without appreciable radial pressure. The forces shall be perpendicular to the levers. The carrier clamp is to be provided with a sufficient number of pins depending on pipe diameter, which fit into holes drilled in the casing. The holes shall not fully penetrate the casing. The service pipe shall be held by any suitable means. See Figure 3. The test shall be carried out at a temperature of $(23 \pm 2) ^\circ\text{C}$.

A tangential force of

$$\frac{F_{\text{tan}}}{2} \tag{3}$$

shall be applied at a distance of 1 000 mm from the centre line of the pipe at each lever in accordance with Figure 3. The speed of the testing machine shall be $v_L = 25 \text{ mm/min}$.

The test result shall be determined as an average value of 3 measurements.

5.4.2.3 Calculation of shear strength

The shear strength is calculated from the following formula:

$$\tau_{\text{tan}} = \frac{F_{\text{tan}}}{\pi \times D_s \times L \times \frac{D_s}{2} \times \frac{1}{a}} \tag{4}$$

where

τ_{tan} = tangential shear strength, in MPa;

F_{tan} = tangential force, in N;

L = length of specimen, in mm;

D_s = outside diameter of the service pipe, in mm;

a = length of each lever, in mm.

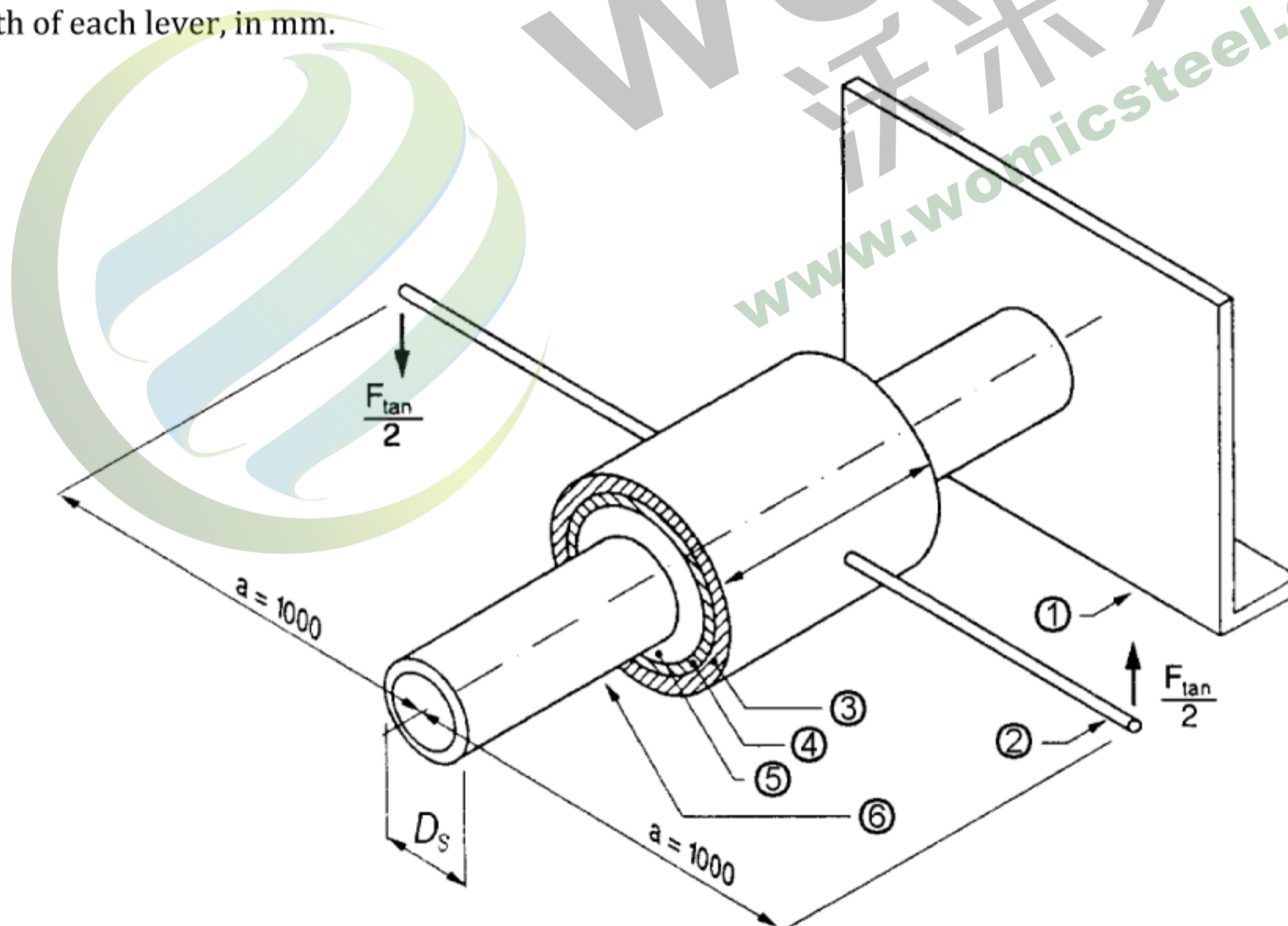

Key

- | | |
|-----------------|----------------|
| 1 Fixture | 4 Casing |
| 2 Lever | 5 Insulation |
| 3 Carrier clamp | 6 Service pipe |

Figure 3 — Tangential shear test arrangement

5.4.3 Shear strength of the pipe assembly after ageing

5.4.3.1 Pipe specimen and ageing

The pipe specimen shall be a length of a pipe assembly at least 3,5 m long. The pipe specimen shall be aged by maintaining the service pipe at a temperature of 160 °C for 3 600 h or alternatively at a temperature of 170 °C for 1 450 h, while the casing is exposed to a temperature of (23 ± 2) °C.

Before ageing, the ends of the foam shall be adequately sealed to prevent air penetration. The service pipe temperature shall be recorded continuously during the ageing period and shall not deviate more than 0,5 °C from the required temperature.

5.4.3.2 Test procedure

After cooling to a temperature of (23 ± 2) °C, the test specimens shall be tested for shear strength in accordance with 5.4.1 or 5.4.2 with the exceptions that test specimens shall be taken from the pipe specimens after ageing and at least 1 000 mm from the pipe ends to exclude material which may be adversely affected by oxygen.

5.4.4 Thermal conductivity in unaged condition

The thermal conductivity (λ_{50}) shall be determined in accordance with EN ISO 8497:1996 and Annex F.

The thermal conductivity shall be determined using a service pipe temperature of (80 ± 10) °C. For type test, the determination of thermal conductivity shall be performed on pipe samples (5 ± 1) weeks after production. The density and cell size shall be measured in accordance with EN 489. The composition of the gas in the cells of the insulation shall be measured according to the Chalmers method²⁾ for analysing the gas phase in polyurethane foam.

5.4.5 Thermal conductivity at artificially aged condition

Before the ageing of the pipe assembly the ends of the foam shall be adequately sealed to prevent gas diffusion. The ageing of the whole pipe assembly shall be performed at 90 ± 1 °C during 150 days. The test shall be performed in accordance with 5.4.4 on the steel pipe dimension DN 50 in 125 mm casing. The laboratory shall prove the sealings to prevent gas diffusion by analysing the composition of the gas in the cells of the insulation.

5.4.6 Impact resistance

A test specimen of the pipe assembly with a length of at least 5 times the outside diameter of the casing shall be tested in accordance with ISO 3127 at a temperature of -20 °C. The falling weight shall have a mass of 3,0 kg, a hemispherical striking surface of 25 mm diameter and be dropped from a height of 2 000 mm.

After having drawn the equidistant lines on the test specimen in accordance with Table 3 of ISO 3127:1994, the test specimen shall be conditioned at a temperature of (-20 ± 1) °C for not less than 3 h before testing. The test shall commence within 10 s of removal from the conditioning apparatus and shall be performed as fast as possible.

5.4.7 Long term creep resistance and modulus at 140 °C

The test specimen shall be taken from a length of a pipe assembly with the dimensions 60,3/125 mm and be taken in accordance with 5.1.2.2 and in the middle of the pipe.

²⁾ The method has been described in the JOURNAL OF CELLULAR PLASTICS, Volume 31, July 1995. Title: A method for analysing the gas phase in polyurethane foam. Authors: O. Ramnäs, M. Svanström

One test specimen consists of one test part, A, and two insulation parts, B, one at each end. The test part shall have a length of 100 mm. The insulation parts shall be made of 50 mm of the original insulation and PE-casing and separated from the test part by two cuts through the PE-casing and the insulation to the steel pipe. The cuts shall be made perpendicular to the axis of the symmetry of the service pipe. See Figure 4.

The test specimen shall be supported at both ends direct beside the insulation parts.

The thickness of the foam shall be measured at a temperature of $(23 \pm 2) ^\circ\text{C}$ and before heating of the pipe is started.

The test shall be carried out with the service pipe kept at a temperature of $(140 \pm 2) ^\circ\text{C}$. This temperature shall be maintained for 500 h before applying the force.

The force $F_{\text{rad}} = 1,50 \pm 0,01 \text{ kN}$ shall be applied constantly and shockless. See Figure 4.

NOTE For information on calculation of the force F_{rad} see Annex E.

The radial displacement, ΔS , of the insulation material shall be measured along the force line in the middle of the test specimen directly on top of the PE-casing. See Figure 5.

The zero-value of the radial displacement, S , shall be measured after the 500 h heating period and immediately before the force F_{rad} is applied.

The displacement shall be measured at 1.000 h and 10.000 h after the load is applied and at least 2 measurements evenly logarithmic distributed in between shall be made. The test results shall be expressed relative as a percentage of the foam thickness and determined as an average value of 3 measurements made on 3 specimens from the same pipe.

The long term creep resistance shall be extrapolated by a straight line in a double logarithmic diagram to 30 years.

The long term creep modulus can be calculated from the creep resistance.

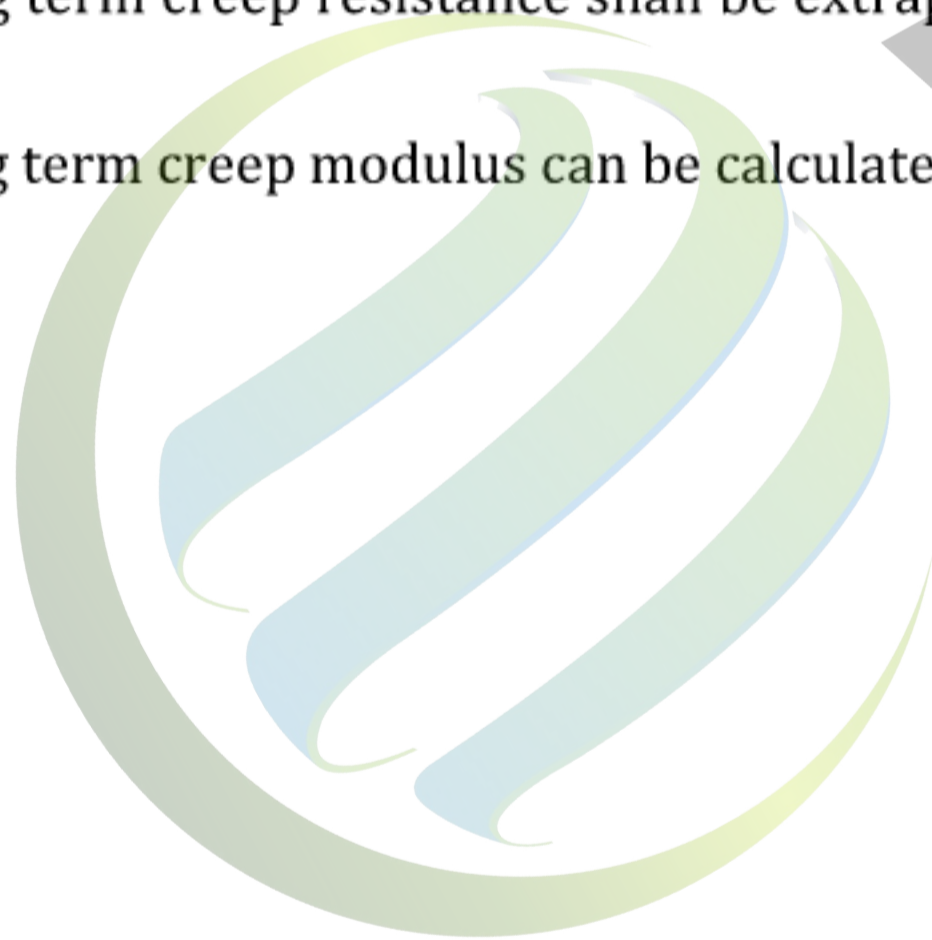

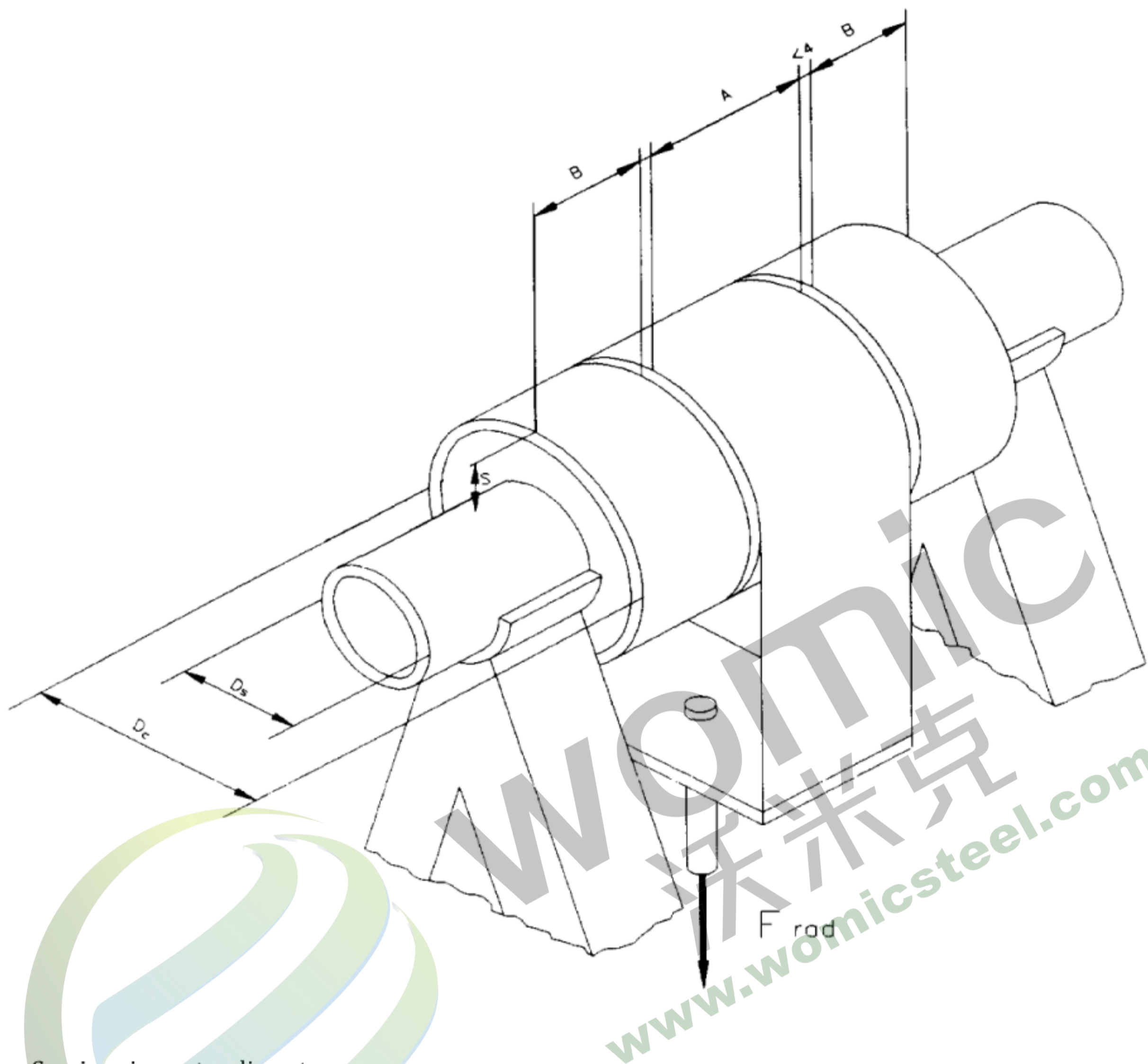

- Key**
- D_s Service pipe outer diameter
 - D_c Outer diameter of the casing
 - A Test part = 100 mm
 - B Insulation part = 50 mm
 - S Zero-value of the radial displacement
 - F_{rad} Radial force

Figure 4 — Test specimen and loading arrangement

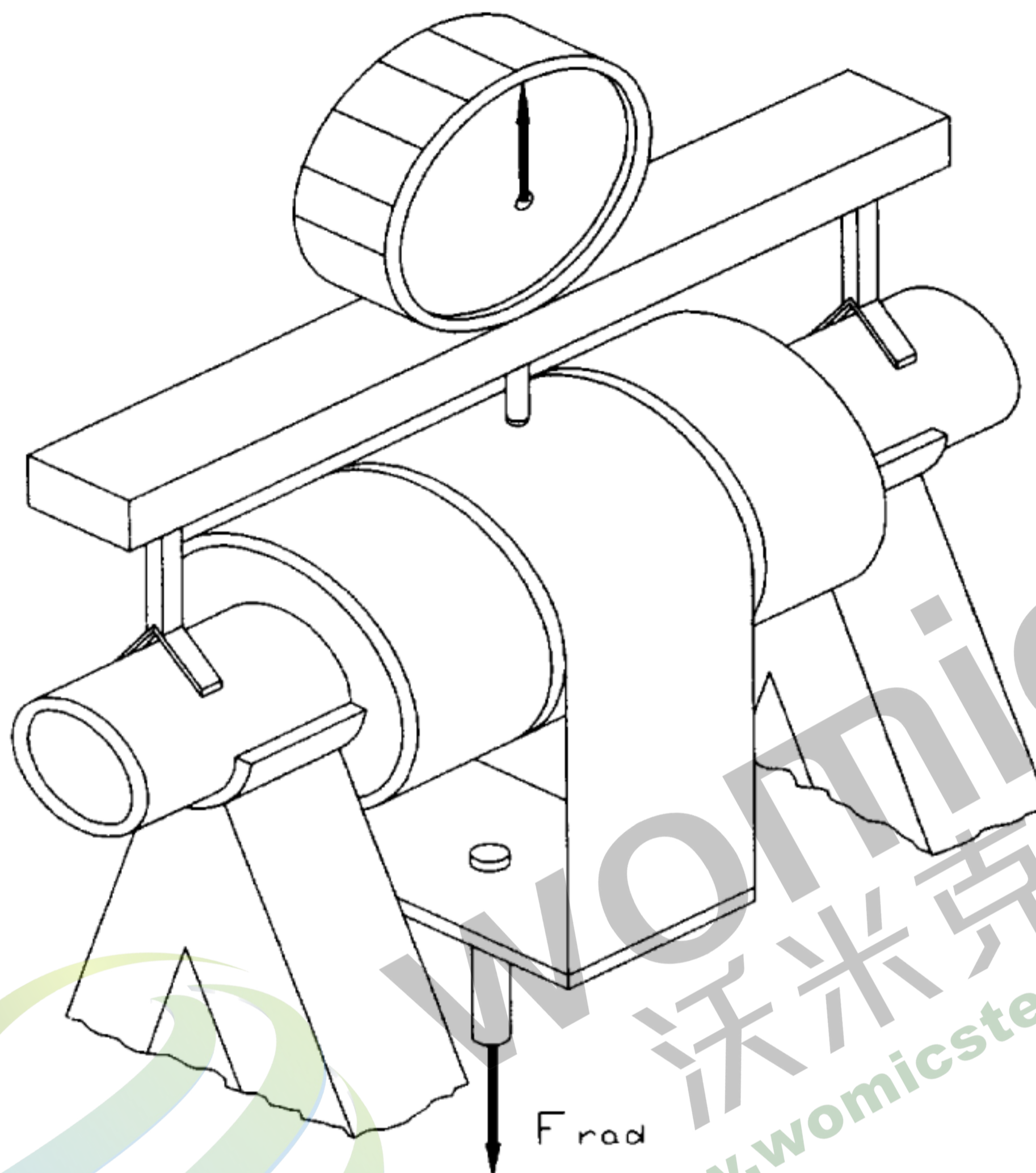

Key
 F_{rad} Radial force

Figure 5 — Measuring arrangement for radial displacement

6 Marking

6.1 General

The pipe shall be marked by any suitable method which does not affect the functional properties of the pipe casing and which is able to withstand conditions of handling, storage and use.

6.2 Steel service pipe

The steel service pipe shall be marked according to the requirements on marking given in the relevant standards EN 10216-2, EN 10217-1, EN 10217-2 or EN 10217-5.

6.3 Casing

The manufacturer of the casing pipe shall mark thereon:

- 1) raw material of the PE, by trade name or code;

- 2) MFR – table value as declared by the raw material supplier;
- 3) nominal diameter and nominal wall thickness of the casing pipe;
- 4) year and week of manufacture;
- 5) manufacturer's identification.

6.4 Pipe assembly

The manufacturer of the pipe assembly shall mark on the casing:

- 1) nominal diameter and nominal wall thickness of the service pipe;
- 2) steel specification and grade;
- 3) manufacturer's identification;
- 4) number of this European Standard;
- 5) year and week of foaming;
- 6) type of physical blowing agent, if any;
- 7) information about the diffusion barrier, if any.



Womic
沃米克
www.womicsteel.com

Annex A
(informative)

Relation between actual continuous operating conditions and accelerated ageing test conditions

The effect of foam ageing on the shear strength of bonded pipe systems was studied by a Working Group of CEN/TC 107. The data of 4.5.5 and 5.4.3 indicating minimum expected life requirements and requirements for shear strength of the pipe assembly after accelerated ageing are based on investigations carried out by this working group and present knowledge and experience with bonded systems which comply to this specification.

These investigations have shown that an Arrhenius equation that relates the logarithm of the expected life of a pipe assembly with the reciprocal value of the absolute continuous operating temperature, can be used to extrapolate test data obtained from ageing tests at temperatures exceeding the normal continuous operating temperatures, to life expectancy at actual operating temperatures. This extrapolation critically depends on the activation energy of the ageing process, and in this standard a value of 150 kJ/(mol × K) is applied. Although this value is based on a number of investigations, further studies are necessary to confirm this.

From the Arrhenius relation illustrated in Figure A.1 it can be concluded that an ageing test of 3 600 h at 160 °C or alternatively 1 450 h at 170 °C is required to comply with the minimum expected life data of 4.5.5.1.

Where hot water networks are to be designed for a minimum of 30 years life with maximum continuous operating temperatures other than 120 °C, the testing temperature or the testing time should be modified.

Based on a testing time of 3 600 h, the testing temperature can be derived from the following formula:

$$\theta' = \frac{1}{(\theta + 273)^{-1} - 2,38 \times 10^{-4}} - 273 \quad (\text{A.1})$$

where

θ' = the test temperature, in °C;

θ = the design 30 years continuous operating temperature, in °C.

Based on a testing temperature of 160 °C, the testing time can be derived from the following formula:

$$T = \exp \left(54,097 - \frac{18\,041,86}{\theta + 273} \right) \quad (\text{A.2})$$

where

T = the testing time, in h;

θ = the design 30 years continuous operating temperature, in °C.

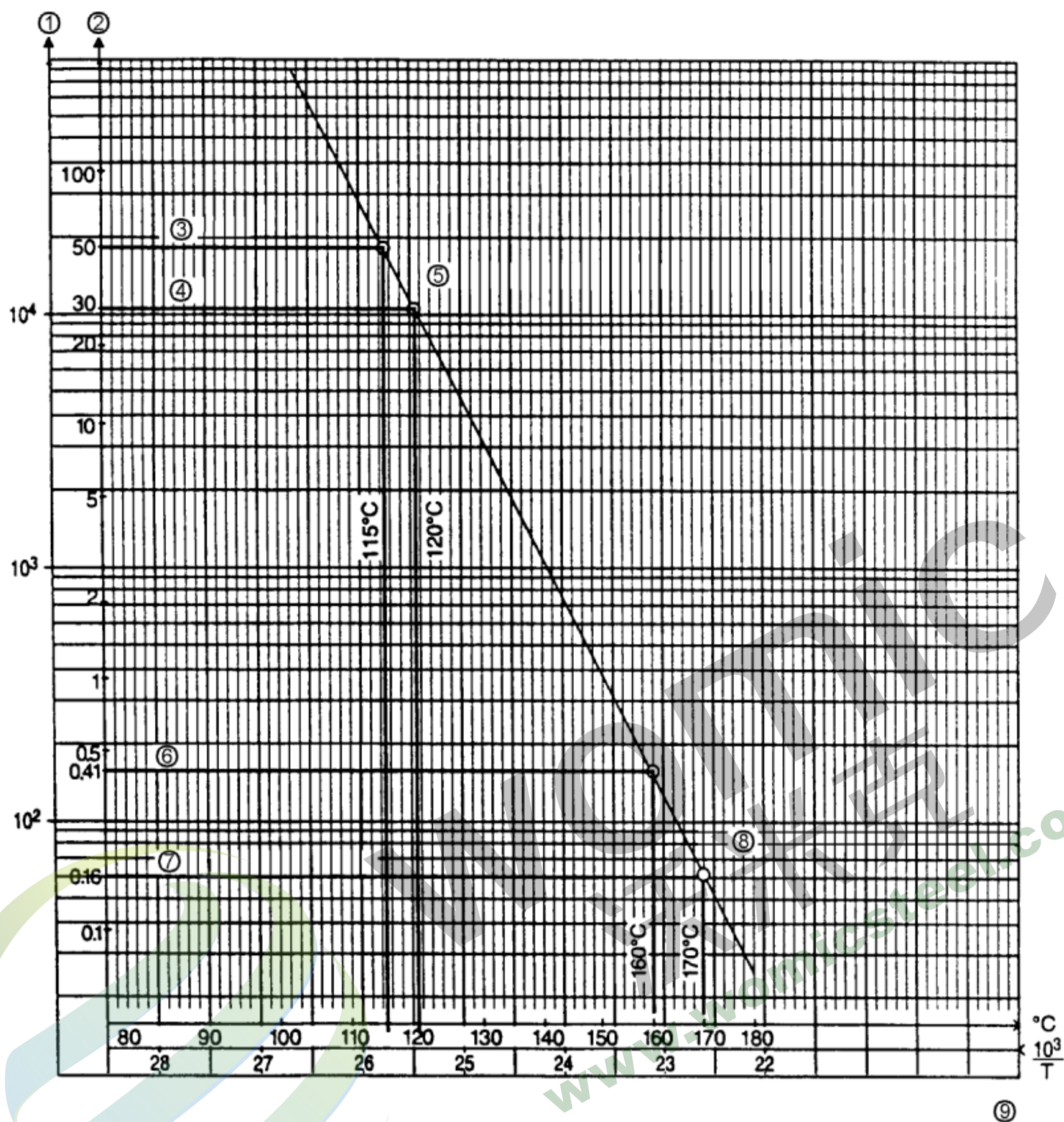

Key

- | | | | |
|---|---|---|---|
| 1 | Expected thermal life (L), days | 6 | 3 600 h |
| 2 | Expected thermal life (L), years | 7 | 1 450 h |
| 3 | 50 years | 8 | Ageing test conditions (cf. 5.4.3) |
| 4 | 30 years | 9 | Continuous operating temperature (θ) |
| 5 | Actual operation conditions (cf. 4.5.5.1) | | |

Figure A.1 — Relationship between the expected thermal life L at a continuous operating temperature (θ) for the minimum requirements outlined in 4.5.5.1 and the accelerated ageing test periods and temperatures outlined in 5.4.3

Annex B
(informative)

Calculation of the minimum expected thermal life with operation at various temperatures with respect to PUR foam performance

The life of the hot water network will depend on the PUR foam and its composition, the service steel pipe, the PE casing as well as on the various mechanical stresses which result from the design of the network and the temperature cycling to which it is subjected in operation.

The following formula applies only for straight pipes in networks subject to gradual and occasional temperature variations (e.g. to match seasonal demands for heat) within the normal operating temperature range indicated in Figure A.1. Mechanical stresses are not considered in the following formula.

Assuming that the operating temperature cycle is about the same every year, the expected thermal life of such pipes can be estimated using the following equation:

$$L = \left(\frac{t_1}{L_1} + \frac{t_2}{L_2} + \dots + \frac{t_n}{L_n} \right)^{-1} \quad (\text{B.1})$$

where

L = expected thermal life of the system, in years;

L_1 = expected thermal life of the system in years if operated continuously at the temperature θ_1 , which can be determined from the Arrhenius plot in Figure A.1;

L_2 = same as above for temperature θ_2 , etc.;

t_1 = annual time fraction that the system is operated at temperature θ_1 ;

t_2 = same as above for temperature θ_2 , etc.

Annex C (normative)

A1 Calculated Continuous Operating Temperature (CCOT)

C.1 General

The purpose of this accelerated ageing method is to evaluate the resistance against thermal degradation of PUR foam in bonded pipe systems.

The principle of the method will generate a value for the CCOT within a testing time of about 1 year.

The limitation of the method is that any additional degradation from present oxygen during life span of bonded pipe systems is not considered.

The use of CCOT outside the scope of this standard shall be restricted to PUR foams which are not exposed to oxygen during operation.

C.2 Principle

Based on tangential shear strength measurements on pipe assemblies aged for at least 1 000 h at three temperatures, as a minimum, and assuming an Arrhenius-type-relationship the calculated continuous operating temperature, CCOT, shall be determined.

The maximum ageing temperature shall correspond to a thermal life of at least 1 000 h and the difference between the maximum and minimum ageing temperatures shall be at least 10 K. The ageing temperature is the temperature of the service pipe, which shall be recorded continuously during the ageing period and which shall never deviate more than 0,5 K from the mean temperature. To prevent gas diffusion during the ageing, the free ends of the pipe assembly shall be adequately sealed.

The determination of the thermal life is based on measurements of the changes in tangential shear strength of the material after temperature load.

The thermal life at each ageing temperature is determined by performing tangential shear tests at 140 °C for a series of increasing ageing times. The thermal life at a specific temperature is defined as the time until the tangential shear strength at 140 °C falls below 0,13 MPa when exposing the pipe continuously to the ageing temperature.

NOTE The limit value for the tangential shear strength, 0,13 MPa, used in the definition of the thermal life is higher than the shear strength level necessary in service. As a consequence the useful service life of the pipe system can be expected to exceed the thermal life value.

The calculated continuous operating temperature is the temperature for which the thermal life 30 years can be calculated assuming an Arrhenius relationship between temperature and thermal life.

C.3 Symbols

T ageing or operating temperature (K)

L thermal life (h)

T_k ageing temperature level (K)

L_k thermal life at temperature level T_k (h)

CCOT calculated continuous operating temperature giving a thermal life of 30 years (K)

C, D regression coefficients

C.4 Ageing and shear strength determinations

The shear strength dependence on ageing times shall be determined for, at least, three temperatures. The ageing temperatures shall differ by at least 3 K and the difference between the highest and lowest ageing temperature shall be not less than 10 K. The service pipe temperature shall not deviate more than 0,5 K from the required temperature.

Before the test, the free ends of the pipe assembly shall be adequately sealed by welding a flange to the steel pipe which can be sealed gas tight to the polyethylene casing.

At each ageing temperature the shear strength shall be determined for a series of ageing times. The tangential shear strength shall be determined at 140 °C at least 500 mm from the pipe ends. One measurement shall be taken for each determination of the shear strength. Measurements shall be made with a maximum interval of 7 d in the period including the last three measurements before and the first three measurements after the shear strength value passes 0,13 MPa.

Determination of the time to start measuring with short intervals (7 d) may be based on experience with similar foam types, on a pre-test or it may be based on results achieved for the actual pipe assembly at higher ageing temperatures. Based on experience, the maximum interval of 7 d is found to give results with adequate precision.

C.5 Calculations

C.5.1 Determination of the thermal life at different ageing temperatures

For each ageing temperature, T_k , plot tangential shear strength values versus ageing times in linear scales. Calculate and plot as a curve the floating mean of five values.

The measured thermal life, L_k , shall be determined as the ageing time at which the floating mean curve first crosses the shear strength level 0,13 MPa. For the calculation of the thermal life the floating mean curve shall be linearly interpolated between the last point before and the first point after the crossing.

C.5.2 Adoption to the Arrhenius relation

Calculate by linear regression from the measured thermal life values, L_k , and the corresponding ageing temperatures, T_k , the coefficients C and D of the Arrhenius relation.

$$\ln L_k = C / T_k + D \quad (C.1)$$

Calculate the correlation coefficient (r)

$$r = \frac{\sum_k [(y_k - \bar{y}_k) \times (x_k - \bar{x}_k)]}{\sqrt{\sum_k (y_k - \bar{y}_k)^2 \times \sum_k (x_k - \bar{x}_k)^2}} \quad (C.2)$$

where

$$x_k = 1 / T_k$$

$$y_k = \ln(L_k)$$

and x_k and y_k are mean values for x_k and y_k respectively.

If the correlation coefficient, r , is less than 0,98, the values are unsuitable for further evaluation. If this is the case the measurements can be extended or repeated to reach a data set giving acceptable regression linearity.

C.5.3 Calculated continuous operating temperature, CCOT

The most probable value for the operating temperature which will give a thermal life of 30 years (262 800 h), is calculated from Formula (C.1)

$$\text{CCOT} = T_{30\text{years}} = C / (\ln 262800 - D) \quad (\text{C.3})$$

For further information concerning the relation between actual continuous operating conditions and accelerated ageing test conditions see Annex A. For further information concerning calculation of the minimum expected thermal life with operation at various temperatures with respect to PUR foam performance see Annex B.

The density, the cell size, the content of closed cells and the physical blowing agent shall be reported together with the CCOT. 



WOMIC
沃米克
www.womicsteel.com

Annex D
(informative)

Guidelines for inspection and testing

D.1 General

The following inspection items and frequencies are recommended to ensure that manufactured preinsulated pipes comply with the requirements specified in this European Standard.

A quality system certified to be in accordance with EN ISO 9001 with reference to EN 253 and the obtained statistics of consistency of test results can be used to adjust inspection frequencies to the actual needs.

The recommended inspection includes the following.

D.2 Manufacturer's type test

A type test is used to obtain an initial validation of materials and production methods. A new type test should be performed where materials or methods are changed essentially.

D.3 Manufacturer's quality control

The manufacturer's quality control is applied to ensure that the intended quality level of the product is maintained. The manufacturer is responsible for ensuring that the tests specified in this European Standard are carried out and the results recorded.

D.4 External inspection

This inspection is primarily intended as an evaluation of the extent and the proper functioning of the manufacturer's quality control. This inspection also includes sampling of products to ensure that the requirements specified in this European Standard are fulfilled. External inspections are normally made at least once a year. The suggested extent of the inspections is given in Tables D.1 to D.4.

D.5 Manufacturer's responsibility

Where a manufacturer of preinsulated pipes makes his own raw material or produces parts on which there is a requirement for 'manufacturer's certificates', the manufacturer of the preinsulated pipes should take over the responsibilities of the supplier.

Table D.1 — Service pipe inspection

Clause	Item	Test frequency			
		Manufacturer's test	type	Manufacturer's quality control	External inspection
4.2.1	Make, marking, delivery specification	None		Receiving inspection procedure	None
4.2.2 4.2.3	Dimensions	None		Receiving inspection procedure	None
4.2.4	Finish, surface, etc.	None		Receiving inspection procedure	None

Table D.2 — Polyethylene-casing inspection

Clause	Item	Test frequency		
		Manufacturer's test	Manufacturer's quality control	External inspection
4.3.1	Material	Inspection of certificates	Per delivery/batch no.: melt mass-flow rate and thermal stability Or: receiving inspection procedure	Inspection of internal test records and certificates for the density
4.3.1.1	Carbon black dispersion	Once per material type Inspection of certificates	Inspection of certificates	Inspection of records
4.3.1.3	Thermal stability	Inspection of certificates	Production batches containing rework material Inspection of records	Inspection of records
4.3.1.4	Use of rework material	None	Inspection of records	None
4.3.2.1	Diameter	Inspection of production records	Min. once per 2 h per extruder Or: receiving inspection procedure	Inspection of records and certificates
4.3.2.2	Wall thickness			
4.3.2.3	Appearance and surface finish	Inspection of records and check of measuring methods	Once per production batch Or: receiving inspection procedure	Inspection of records and check of measuring methods
4.3.2.4	Elongation at break	Inspection of internal records. One sample taken each from three different pipe sizes	Once per production batch containing rework material	Inspection of internal records
4.3.2.5	Heat reversion	One sample taken each from three different pipe sizes	None	None
4.3.2.6	Stress crack resistance	Once per material type	Min. 4 tests per material type per year, equally distributed over used extruders and yearly production.	Inspection of internal records



Table D.3 — Polyurethane foam insulation (PUR) inspection

Clause	Item	Test frequency		
		Manufacturer's type test	Manufacturer's quality control	External inspection
4.4.1	Composition Make, marking and delivery specifications	Inspection of documentation	Inspection of machine settings: Min. once a day Inspection of production parameters: once per raw material batch or receiving inspection procedure	Inspection of internal records
4.4.2	Cell structure - Cell size	Once per polyol/isocyanate type per machine	Min. twice a year per machine	Once per inspection visit Inspection of internal records
4.4.2	Cell structure - Closed cell content	Once per polyol/isocyanate type per machine	Min. twice a year per machine	Once per inspection visit Inspection of internal records
4.4.2	Cell structure - Voids and bubbles	Once by taking out of pipe for other test	Min. twice a year per machine	Once per inspection visit Inspection of internal records
4.4.3	Compressive strength	Once per polyol/isocyanate type per machine	Once a month per machine	Once per inspection visit Inspection of internal records
4.4.4	Density	Once per polyol/isocyanate type per machine	Once per shift per machine	Once per inspection visit Inspection of internal records
4.4.5	Water absorption	Once per polyol/isocyanate type per machine	Min. once a year per machine	Once per inspection visit Inspection of internal records
<p>In type and external inspection test reports all PUR-properties should be reported together with the density of the PUR-foam.</p> <p>For type test of the thermal conductivity, 4.5.6 and 4.5.7 the result shall be reported together with the foam density, cell size, compressive strength and the composition of the gas in the cells of the insulation based on the same pipe sample.</p>				



Table D.4 — Pipe assembly inspection

Clause	Item	Test frequency		
		Manufacturer's type test	Manufacturer's quality control	External inspection
4.5.2 4.5.3	Dimensions of pipe ends and outside diameter	Measured on one pipe per dimension	Measured min. once per shift per dimension	Once per inspection visit Inspection of internal records
4.5.4	Centre line deviation	Once by taking out of pipe for other tests	Min. twice a year	Once per inspection visit Inspection of internal records
4.5.5.2	Shear strength before ageing	Once by taking out of pipe for other tests	None	Once per inspection visit per polyol/isocyanate type
4.5.5.2	Shear strength after ageing	Once per polyol/isocyanate type per machine	None	None
4.5.6	Thermal conductivity in unaged condition	Once per polyol/isocyanate type	None	Once per inspection visit
4.5.7	Thermal conductivity in artificially aged condition	Once per polyol/isocyanate type	None	None
4.5.8	Impact resistance	Once on pipe of each casing material/supplies	None	Once per inspection visit on a pipe taken out for other tests
4.5.9	Long term creep resistance and modulus	Once per polyol/isocyanate type	None	None
4.5.11	Measuring wires	See EN 14419.	See EN 14419.	See EN 14419.
NOTE	In type and external inspection test reports the results for item 4.5.5 to 4.5.9 should be reported together with the density of the PUR-foam.			

Annex E
(informative)

Radial creep behaviour of the polyurethane foam (PUR)

The test of creep behaviour in 5.4.7 is a type test for a specific type of insulation material.

The test shall be carried out on a preinsulated pipe with dimensions 60,3/125 mm.

The test method and the requirements are based on experience from samples with the service pipe dimension of 60,3 mm. Thus the applied force F_{rad} can be calculated as the pipe diameter times sample length times the load:

$$F_{\text{rad}} = 60,3 \times 100 \times 0,25 = 1\,508 \text{ N} = 1,5 \text{ kN} \quad (\text{E.1})$$

where

F_{rad} = the applied force in kN

60,3 = the outside diameter of the service pipe in mm

100 = the sample length of the casing in mm

0,25 = the conservatively chosen load in MPa



WOMIC
沃米克
www.womicsteel.com

Annex F (normative)

Thermal conductivity of pre-insulated pipes - Test procedure

F.1 Scope

This Annex describes together with EN ISO 8497:1996 a method for the determination of steady-state thermal conductivity of polyurethane foam in pre-insulated district heating pipes.

F.2 Requirements (EN ISO 8497:1996, Clause 5)

F.2.1 Test specimen (EN ISO 8497:1996, 5.1)

The pipe shall have a circular cross section. For type-test a test specimen with a length not less than 3 m shall be taken from the middle of a pipe assembly with the dimension 60,3/125 mm.

F.2.2 Operating temperature (EN ISO 8497:1996, 5.2)

The apparatus shall operate in still air maintained at an ambient temperature of (23 ± 2) °C.

F.2.3 Types of apparatus (EN ISO 8497:1996, 5.5)

Guarded end, calibrated and calculated end-cap apparatus can be used.

F.3 Apparatus (EN ISO 8497:1996, Clause 7)

F.3.1 Guarded end apparatus

The guarded end apparatus uses separately heated pipe sections, called "guards", located at each end of the metered test section which shall be maintained at the test section temperature to eliminate axial heat flow in the apparatus, and to aid in achieving uniform temperatures so that all heat flow in the specimen test section will be in the radial direction. Both test and guard section heaters shall be designed to achieve uniform temperatures over their lengths unless it has been shown that the expected deviation from temperature uniformity does not cause unacceptable errors in test results.

A gap, normally not more than 4 mm in width, shall be provided in the heater pipe between the guards and the test section. A similar gap shall also be provided in the steel pipe of the test specimen between the metered section and the guard sections.

Internal barriers shall be installed at each gap to minimise convection and radiation heat transfer between sections. Thermocouples, connected as differential thermopiles, shall be installed in the heater pipe on both sides of each gap, and not more than 25 mm from the gap, for the purpose of monitoring the temperature differential across each gap.

F.3.2 Calibrated end apparatus

When calibrated or calculated end-cap apparatus are used the heat loss through the end-caps shall be stated in the report.

F.3.3 Dimensions (EN ISO 8497:1996, 7.2)

No restriction is placed on the heater pipe diameter, but the length of the test section shall be not less than 1,0 m for the guarded end apparatus and not less than 2,0 m for calibrated and calculated end-cap apparatus.

F.3.4 Heater pipe surface temperature

The surface temperature of the heater pipe test section shall be measured by a minimum number of 4 temperature sensors equally spaced along the test pipe section.

F.4 Test specimens (EN ISO 8497:1996, Clause 8)

F.4.1 Conditioning (EN ISO 8497:1996, 8.4)

The test specimen shall be conditioned at a temperature of (23 ± 2) °C for 1 week. For type-test the thermal conductivity shall be performed on a pipe sample, stored at a temperature of (23 ± 2) °C for (5 ± 1) weeks after production.

F.4.2 Dimension measurement (EN ISO 8497:1996, 8.5)

The inside and outside diameters of the service pipe (D_{s1}) and (D_{s2}) shall be measured with a slide calliper. The casing shall be measured with a flexible steel tape to obtain the circumference, which is divided by π to obtain the outside diameter (D_{c4}), in at least 4 equally spaced positions along the test specimen.

The thickness of the casing (t) shall be measured at 4 points equally spaced around the circumference at both ends of the specimen and the inside diameter (D_{c3}) is then calculated.

F.4.3 Surface temperature measurement

Sensors for measuring the temperature of the specimen shall be attached to the service pipe inner surface and casing outer surface.

F.4.4 Location of temperature sensors (EN ISO 8497:1996, 8.6)

The test section length shall be divided into at least 4 equal parts and at least one temperature sensor at the steel pipe and at the casing shall be longitudinally located at the centre of each part. The sensors shall be circumferentially equally spaced.

F.5 Procedure (EN ISO 8497:1996, Clause 9)

F.5.1 Test length (EN ISO 8497:1996, 9.1.1)

The actual test length (L), not less than 1,0 m for guarded end apparatus and not less than 2,0 m for calibrated and calculated end-cap apparatus shall be measured. Accuracy: $\pm 1,0$ mm.

F.5.2 Diameter (EN ISO 8497:1996, 8.5)

The mean outside diameter of the casing shall be obtained by measuring the circumference with a flexible steel tape. The outside diameter of the steel pipe shall be measured with a slide calliper.

Accuracy: Casing diameter $\pm 0,1$ mm

Service pipe diameter $\pm 0,1$ mm.

F.5.3 Thickness of casing

The thickness of the casing shall be measured with a slide calliper.

Accuracy: $\pm 0,1$ mm.

F.5.4 Ambient requirements (EN ISO 8497:1996, 9.2)

Operate the apparatus in a room or enclosure controlled to the desired ambient temperature, $(23 \pm 2) ^\circ\text{C}$, so that it does not vary during a test by more than $\pm 1 ^\circ\text{C}$. The test shall be run in essentially still air.

F.5.5 Test pipe temperature (EN ISO 8497:1996, 9.3)

Tests are to be run at a minimum of three service pipe temperatures. Accuracy of temperature measurements shall be within $\pm 0,3 ^\circ\text{C}$. For type test the temperatures shall be approximately equally spaced in the temperature interval $70 ^\circ\text{C}$ to $90 ^\circ\text{C}$ measured at the inside surface of the service pipe.

F.5.6 Power supply (EN ISO 8497:1996, 7.9)

The accuracy of the power measuring system to the test section heater shall be within 1,0 %.

A₂

F.5.7 Axial heat loss **A₂**

When guarded end apparatus is used reject any tests where the axial heat flow at either end is estimated to be more than 0,5 % of the mean heat input to the test section. When calibrated and calculated end-cap apparatus are used the heat loss through the end caps shall be determined and reported.

F.5.8 Test period and stability (EN ISO 8497:1996, 9.5.3)

Continue the observations until at least three successive sets of observations, made with a minimum time interval of 0,5 h between each set, differ by no more than 1 % from the mean value of the three sets, and do not exhibit unidirectional trends. Where the power measurement is made with an integrating instrument, each observation shall be of minimum 0,5 h duration.

F.6 Calculations (EN ISO 8497:1996, Clause 11)

F.6.1 Thermal conductivity (EN ISO 8497:1996, 3.5)

The thermal conductivity at the mean temperature in the insulation material shall be calculated by linear regression using the results obtained at the different pipe temperatures. The result is reported as λ at the mean temperature (T_m). For type test, the thermal conductivity λ_{50} shall be determined as an average of three different pipe assemblies. The thermal conductivity shall be rounded to the nearest 1/1 000 W/(m × K).

Appropriate correction shall be made to the temperature drop in the casing (thermal conductivity of the HD-polyethylene is stated to be 0,40 W/(m × K). Any correction for the temperature drop in the steel service pipe can be neglected ($\lambda_{\text{steel}} = 50^3$) W/(m × K)). If other materials are used as service pipe material, corrective calculations have to be made.

³⁾ EN 12524

F.7 Symbols and units (EN ISO 8497:1996 Clause 4)

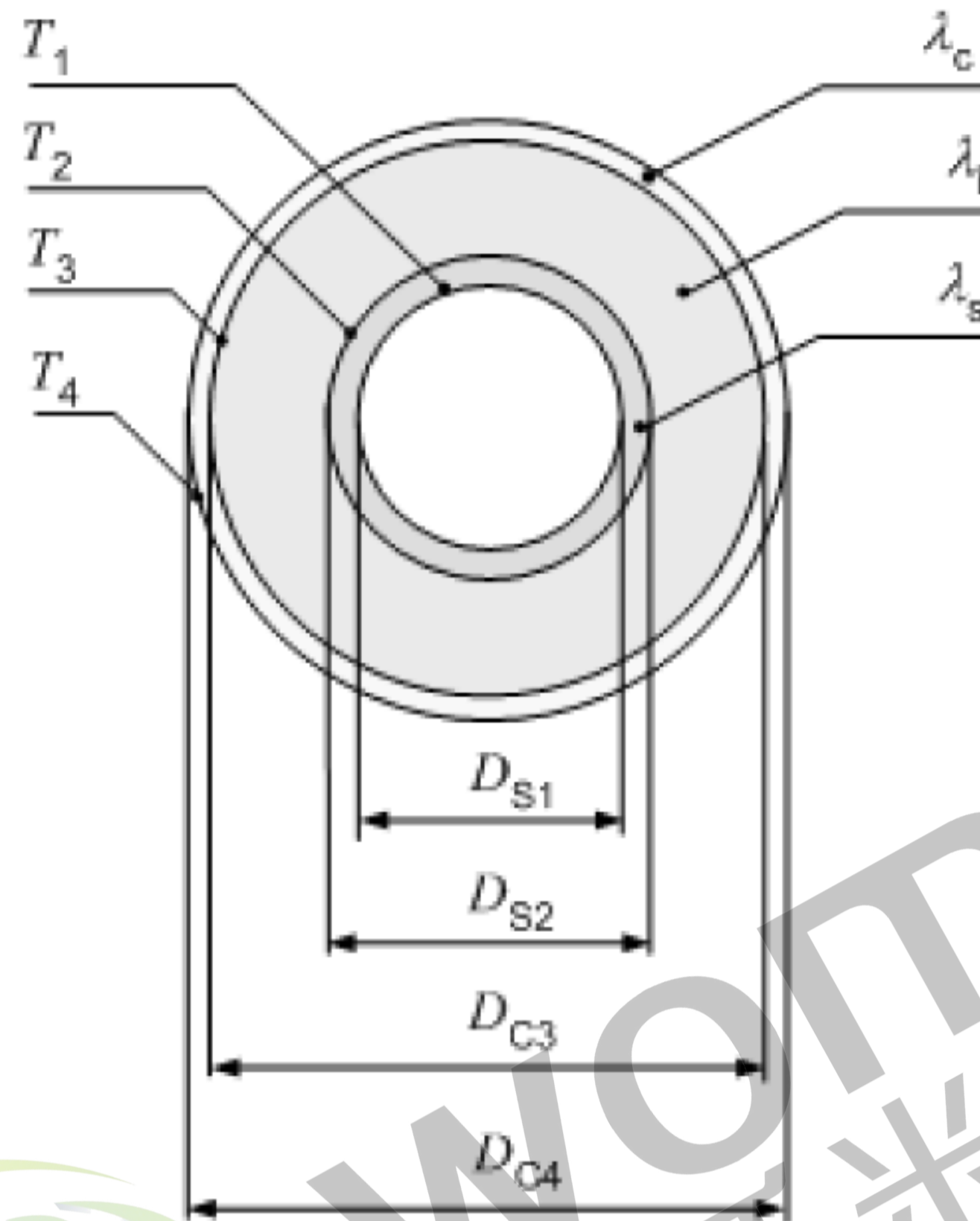

Figure F.1 — Symbols

Table F.1 — Symbols and units

Heat flow rate	Φ	(W)
Test section length	L	(m)
Temperature of service pipe inner surface	T_1	(°C)
Temperature of insulation inner surface	T_2	(°C)
Temperature of insulation outer surface	T_3	(°C)
Temperature of casing outer surface	T_4	(°C)
Mean temperature of the insulation	T_m	(°C)
Service pipe inner diameter	D_{s1}	(m)
Inner diameter of insulation material	D_{s2}	(m)
Outer diameter of insulation material	D_{c3}	(m)
Outer diameter of casing	D_{c4}	(m)
Thickness of casing	t	(m)
Thermal conductivity of insulation material	λ_i	(W/(m × K))
Thermal conductivity of casing	λ_c	(W/(m × K))
Thermal conductivity of service pipe	λ_s	(W/(m × K))

$$\lambda_i = \frac{\ln\left(\frac{D_{c3}}{D_{s2}}\right)}{\frac{2 \times \pi \times (T_1 - T_4) \times L}{\Phi} - \frac{1}{\lambda_c} \ln\left(\frac{D_{c4}}{D_{c3}}\right) - \frac{1}{\lambda_s} \ln\left(\frac{D_{s2}}{D_{s1}}\right)} \quad (\text{F.1})$$

$$T_3 = T_4 + \frac{\Phi}{2 \times \pi \times L \times \lambda_c} \ln\left(\frac{D_{c4}}{D_{c3}}\right) \quad (\text{F.2})$$

$$T_m = \frac{(T_3 + T_2)}{2} \quad (\text{F.3})$$

$$T_2 = T_1 - \frac{\Phi}{2 \times \pi \times L \times \lambda_s} \ln\left(\frac{D_{s2}}{D_{s1}}\right) \quad (\text{F.4})$$



Womic
沃米克
www.womicsteel.com

Annex G (informative)

National A-deviations

A-deviation: National deviation due to regulations, the alteration of which is for the time being outside the competence of the CEN/CENELEC member.

This European Standard does not fall under any Directive of the EC. In the relevant CEN countries these A-deviations are valid instead of the provisions of the European Standard until they have been removed.

G.1 Swedish national legislative deviations on steel service pipes

According to the Provisions AFS 2005:2 (*on Vessels, Piping and Installations*) of the Swedish Work Environment Authority the pipe steel grades P235TR1 and P235TR2 according to EN 10217-1:2002 must not be used for piping of requirement G according to AFS 2005:2. Piping of requirement G has to fulfill the essential safety requirements in annex 1 of AFS 2005:2. For use in district heating piping systems it is necessary according to annex 1 of AFS 2005:2 to have specified material property values for elevated temperatures up to at least +120 °C and EN 10217-1:2002, *Welded steel tubes for pressure purposes - Technical delivery conditions - Part 1: Non-alloy steel tubes with specified room temperature properties*, does not have any such material properties specified above room temperature. Pipe steel grade P235TR1 according to EN 10217-1:2002 does also not have any specified impact energy requirements, which also is an essential safety requirement of annex 1 in AFS 2005:2.

For welded steel pipes of requirement K according to AFS 2005:2 to be used in Sweden, the welding procedures and the welding personnel must be assessed and approved by a control and certification body respectively as provided for in Section 22 of AFS 2005:2. This control body and a certification body shall have obtained accreditation for the task in question under the Swedish Technical Inspection Act (SFS 1992:1119). Control and certification can also be performed by a control agency and certification body respectively from another country within the EEA (European Economic Area), if

- 1) the control body is accredited for the task with reference to the requirements of the relevant standard in the EN 45000 series by an accrediting body which meets and applies to this assessment the requirements of ISO/TR 17010 or otherwise offers corresponding guarantees with regard to technical and professional competence and guarantees of independence.
- 2) the certification body is accredited for the task with reference to the requirements of the relevant standard in the EN 45 000 series by an accrediting body which meets and applies to this assessment the requirements of EN 45 010 or otherwise offers corresponding guarantees with regard to technical and professional competence and guarantees of independence.

Non-destructive testing of the welds in welded steel pipes of requirement K according to AFS 2005:2, must have been carried out by a laboratory pursuant to Section 22. The laboratory shall have obtained accreditation for the task in question under the Swedish Technical Inspection Act (SFS 1992:1119). Non-destructive testing can also be performed by a laboratory from another country within the EEA (European Economic Area), if the laboratory is accredited for the task with reference to the ISO/IEC 17025 standard by an accrediting body which meets and applies for assessment the requirements of EN 45 010 or otherwise offers corresponding guarantees of technical and professional competence and independence.

Annex H (informative)

Main changes from the previous edition of EN 253

The main changes from EN 253:2003 are:

- 1) the following changes to the requirements on the casing made to EN 253:2003 by the endorsement of EN 253:2003/A1:2005 have been incorporated in the main standard:
 - a) the term "casing pipe" has been changed as far as possible to "casing";
 - b) the minimum wall thicknesses for the casing have been reduced;
 - c) the description of tolerances on casing diameter and wall thickness has been changed;
 - d) the test method for increase of casing during foaming has been omitted;
- 2) the following changes made to the requirements on the steel service pipe material made to EN 253:2003 by the endorsement of EN 253:2003/A2:2006 have been incorporated:
 - a) the material specification for steel service pipes has been extended to include the steel P235TR1 according to EN 10217-1 and a method for calculation of the yield stress $R_{p0,2}$ for the new material when used at temperatures up to 140 °C has been added;
- 3) the possibility to include additional elements such as measuring wires, spacers and diffusion barriers in the pipe assembly, has been mentioned in the Scope;
- 4) the references to other standards were changed to be in line with the latest versions of the standards;
- 5) definitions were added for terms "artificial ageing", "diffusion barrier", "fusion compatibility", "physical blowing agent" and "virgin material";
- 6) the definition of "lot" was omitted;
- 7) the requirements for the steel quality was amended by the addition of a reference to the steel P235TR2 according to EN 10217-1;
- 8) steel service pipes in DN 15 have been added;
- 9) the requirement on density of the polyethylene casing and the corresponding test method have been omitted;
- 10) the specification of carbon black material added to the casing material has been omitted;
- 11) the requirements on melt flow rate of the casing material have been changed;
- 12) the limitation of the amount of rework material allowed for the manufacturing of the casing has been omitted;
- 13) the requirements on long-term mechanical properties of the polyethylene raw material and the corresponding test methods have been omitted;

- 14) testing of the the elongation at break for the casing material has been changed and is now valid only for casings produced partly or fully from rework material;
- 15) the diameter groups of the casing dimensions have been omitted;
- 16) the requirements on cell structure for the PUR foam have been changed;
- 17) the sampling procedure and acceptance criteria for retest of cell structure (voids and bubbles) have been omitted;
- 18) the requirements on foam density for the PUR foam have been omitted;
- 19) the requirement on water absorption at elevated temperature for the PUR foam has been omitted;
- 20) it has been mentioned that all requirements on the pipe assembly are valid including the diffusion barrier, if any;
- 21) the requirements on shear strength of the pipe assembly have been editorially revised to be more clear;
- 22) the requirement on thermal conductivity (λ_{50}) has been changed to 0,029 W/(m × K);
- 23) requirements on thermal conductivity at artificially aged condition have been added;
- 24) the requirements on creep behaviour have been changed to requirements on long term creep resistance and modulus and the corresponding test method has been adapted accordingly;
- 25) requirements on measuring wires for surveillance systems have been added though a reference to EN 14419;
- 26) it has been specified which tests shall be performed including the diffusion barrier;
- 27) the name of the "notched constant load test" has been changed to "stress crack resistance test";
- 28) the shear strength tests have been editorially revised to be more clear;
- 29) the test method for thermal conductivity (λ_{50}) has been adapted to the requirements on thermal conductivity in unaged condition and thermal conductivity at artificially aged condition;
- 30) the requirement on marking of the pipe assembly has been added to include physical blowing agent and information about the diffusion barrier, if any;
- 31) in Annex D the term "manufacturer's quality surveillance" has been changed to "manufacturer's quality control";
- 32) the items and test frequencies recommended by Annex D have been adapted to the changes concerning requirements and test methods as mentioned above;
- 33) the informative Annex E, Change of blowing agent and influence on thermochemical and thermomechanical properties of polyurethane rigid foam (PUR), has been omitted;
- 34) the normative Annex F have been redesignated E and made informative. The content of this Annex have been changed following amendments in clause 5.4.7 on long term creep resistance and modulus at 140 °C.

- 35) in Annex F, Thermal conductivity of pre-insulated pipes - Test procedure, the requirement for procedures for reporting the heat loss through the end caps have been changed;
- 36) in Annex G, National A-deviations, the Swedish national legislative deviations on steel service pipes have been changed.
- 37) Annex I dealing with waste treatment and recycling has been added.



Womic
沃米克
www.womicsteel.com

Annex I
(informative)

Waste treatment and recycling

Necessary requirements for waste management and recycling of materials used for district heating pipes shall be stated in the manufacturer's documentation and be submitted to the purchaser.



Womic
沃米克
www.womicsteel.com

Bibliography

- [1] "A method for analysing the gas phase in polyurethane foam" by O. Ramnäs, M. Svanström. JOURNAL OF CELLULAR PLASTICS, Volume 31, July 1995
- [2] EN ISO 9001, *Quality management systems – Requirements (ISO 9001:2000)*
- [3] *Statute Book of the Swedish Work Environment Authority AFS 2005:2*



Womic
沃米克
www.womicsteel.com

British Standards Institution (BSI)

BSI is the national body responsible for preparing British Standards and other standards-related publications, information and services.

BSI is incorporated by Royal Charter. British Standards and other standardization products are published by BSI Standards Limited.

About us

We bring together business, industry, government, consumers, innovators and others to shape their combined experience and expertise into standards-based solutions.

The knowledge embodied in our standards has been carefully assembled in a dependable format and refined through our open consultation process. Organizations of all sizes and across all sectors choose standards to help them achieve their goals.

Information on standards

We can provide you with the knowledge that your organization needs to succeed. Find out more about British Standards by visiting our website at bsigroup.com/standards or contacting our Customer Services team or Knowledge Centre.

Buying standards

You can buy and download PDF versions of BSI publications, including British and adopted European and international standards, through our website at bsigroup.com/shop, where hard copies can also be purchased.

If you need international and foreign standards from other Standards Development Organizations, hard copies can be ordered from our Customer Services team.

Subscriptions

Our range of subscription services are designed to make using standards easier for you. For further information on our subscription products go to bsigroup.com/subscriptions.

With **British Standards Online (BSOL)** you'll have instant access to over 55,000 British and adopted European and international standards from your desktop. It's available 24/7 and is refreshed daily so you'll always be up to date.

You can keep in touch with standards developments and receive substantial discounts on the purchase price of standards, both in single copy and subscription format, by becoming a **BSI Subscribing Member**.

PLUS is an updating service exclusive to BSI Subscribing Members. You will automatically receive the latest hard copy of your standards when they're revised or replaced.

To find out more about becoming a BSI Subscribing Member and the benefits of membership, please visit bsigroup.com/shop.

With a **Multi-User Network Licence (MUNL)** you are able to host standards publications on your intranet. Licences can cover as few or as many users as you wish. With updates supplied as soon as they're available, you can be sure your documentation is current. For further information, email bsmusales@bsigroup.com.

BSI Group Headquarters

389 Chiswick High Road London W4 4AL UK

Revisions

Our British Standards and other publications are updated by amendment or revision.

We continually improve the quality of our products and services to benefit your business. If you find an inaccuracy or ambiguity within a British Standard or other BSI publication please inform the Knowledge Centre.

Copyright

All the data, software and documentation set out in all British Standards and other BSI publications are the property of and copyrighted by BSI, or some person or entity that owns copyright in the information used (such as the international standardization bodies) and has formally licensed such information to BSI for commercial publication and use. Except as permitted under the Copyright, Designs and Patents Act 1988 no extract may be reproduced, stored in a retrieval system or transmitted in any form or by any means – electronic, photocopying, recording or otherwise – without prior written permission from BSI. Details and advice can be obtained from the Copyright & Licensing Department.

Useful Contacts:

Customer Services

Tel: +44 845 086 9001

Email (orders): orders@bsigroup.com

Email (enquiries): cservices@bsigroup.com

Subscriptions

Tel: +44 845 086 9001

Email: subscriptions@bsigroup.com

Knowledge Centre

Tel: +44 20 8996 7004

Email: knowledgecentre@bsigroup.com

Copyright & Licensing

Tel: +44 20 8996 7070

Email: copyright@bsigroup.com